

# SHARP • Roku TV

HD LED 720p TV (32" model)

LC-32LB601U / LC-32LB601C

Full HD LED 1080p TV (40" model)

LC-40LB601U

## USER GUIDE

HD

32" / 40"

CLASS

(31.5" Diagonal)

(39.6" Diagonal)

# Contents

---

|  |    |
|--|----|
| CHILD SAFETY .....   | 4  |
| Important Safety Instructions .....                          | 5  |
| WARNING .....  | 5  |
| CAUTION .....  | 6  |
| Welcome .....  | 7  |
| The new standard in Smart TVs.....                           | 7  |
| Get the most out of your new TV .....                        | 7  |
| Accessibility (U.S. models only) .....                       | 8  |
| Installing the stands or wall-mount bracket .....            | 9  |
| Installing the stands .....                                  | 9  |
| Installing a wall-mount bracket .....                        | 10 |
| TV components .....  | 12 |
| Package contents .....                                       | 12 |
| Front features .....   | 12 |
| Side jacks .....   | 13 |
| Back jacks .....   | 13 |
| Remote control .....   | 14 |
| What connection should I use? .....                          | 16 |
| Connecting a cable or satellite box .....                    | 17 |
| HDMI® (best) .....   | 17 |
| AV (good) .....  | 18 |
| Coaxial (good).....  | 19 |
| Connecting an antenna or cable TV (no box) .....             | 20 |
| Connecting a DVD or Blu-ray player .....                     | 21 |
| HDMI® (best) .....   | 21 |
| AV (good) .....  | 22 |
| Connecting a game console .....                              | 23 |
| HDMI® (best) .....   | 23 |
| AV (good) .....  | 24 |
| Connecting a computer .....                                  | 25 |
| Connecting a USB flash drive .....                           | 26 |
| Connecting headphones .....                                  | 27 |
| Connecting external speakers or a sound bar .....            | 28 |
| Digital audio using the DIGITAL OPTICAL OUTPUT jack.....     | 28 |
| Digital audio using the HDMI 1 (ARC) jack .....              | 29 |
| Analog audio using the AUDIO OUT jack .....                  | 30 |
| Connecting a home theater system with multiple devices ..... | 31 |

|   |    |
|---|----|
| Connecting power .....                              | 32 |
| Installing remote control batteries .....           | 33 |
| Aiming the remote control.....                      | 33 |
| Setting up your TV .....                            | 34 |
| Using your TV .....                                 | 34 |
| Maintaining .....                                   | 34 |
| Cleaning your TV cabinet .....                      | 34 |
| Cleaning your TV screen .....                       | 34 |
| Troubleshooting .....                               | 35 |
| FAQ.....  | 35 |
| Video and audio.....                                | 35 |
| Remote control.....                                 | 38 |
| General .....                                       | 39 |
| Roku .....  | 40 |
| Network.....  | 40 |
| CEC-compatible devices .....                        | 41 |
| Specifications .....                                | 43 |
| 32-inch (LC-32LB601U/LC-32LB601C) .....             | 43 |
| 40-inch (LC-40LB601U) .....                         | 44 |
| Legal notices .....                                 | 45 |
| One-year limited warranty - Sharp Televisions ..... | 49 |

# CHILD SAFETY

## PROPER TELEVISION PLACEMENT MATTERS



### THE CONSUMER ELECTRONICS INDUSTRY CARES

- Manufacturers, retailers, and the rest of the consumer electronics industry are committed to making home entertainment safe and enjoyable.
- As you enjoy your television, please note that all televisions - new and old - must be supported on proper stands or installed according to the manufacturer's recommendations. Televisions that are inappropriately situated on dressers, bookcases, shelves, desks, speakers, chests, carts, etc., may fall over, resulting in injury.

### TUNE IN TO SAFETY

- **ALWAYS** follow the manufacturer's recommendations for the safe installation of your television.
- **ALWAYS** read and follow all instructions for proper use of your television.
- **NEVER** allow children to climb on or play on the television or the furniture on which the television is placed.
- **NEVER** place the television on furniture that can easily be used as steps, such as a chest of drawers.
- **ALWAYS** install the television where it cannot be pushed, pulled over, or knocked down.
- **ALWAYS** route cords and cables connected to the television so that they cannot be tripped over, pulled, or grabbed.

### WALL OR CEILING MOUNT YOUR TELEVISION

- **ALWAYS** contact your retailer about professional installation if you have any doubts about your ability to safely mount your television.
- **ALWAYS** use a mount that has been recommended by the television manufacturer and has a safety certification by an independent laboratory (such as UL, CSA, ETL).
- **ALWAYS** follow all instructions supplied by the television and mount manufacturers.
- **ALWAYS** make sure that the wall or ceiling where you are mounting the television is appropriate. Some mounts are not designed to be mounted to walls and ceilings with steel studs or cinder block construction. If you are unsure, contact a professional installer.
- Televisions can be heavy. A minimum of two people is required for a wall or ceiling mount installation.

### MOVING AN OLDER TELEVISION TO A NEW PLACE IN YOUR HOME

- Many new television buyers move their older CRT televisions into a secondary room after the purchase of a flat-panel television. Special care should be made in the placement of older CRT televisions.
- **ALWAYS** place your older CRT television on furniture that is sturdy and appropriate for its size and weight.
- **NEVER** place your older CRT television on a dresser where children may be tempted to use the drawers to climb.
- **ALWAYS** make sure your older CRT television does not hang over the edge of your furniture.

Consumer  
Technology  
Association™

# SHARP • Roku TV

## Important Safety Instructions



This symbol indicates that dangerous voltage constituting a risk of electric shock is present within your TV. This label is located on the back of your TV.



This symbol indicates that there are important operating and maintenance instructions in the literature accompanying your TV.



This symbol indicates that this product incorporates double insulation between the hazardous main voltage and user accessible parts. When servicing, use only identical replacement parts.

- 1 Read these instructions.
- 2 Keep these instructions.
- 3 Heed all warnings.
- 4 Follow all instructions.
- 5 Do not use this apparatus near water.
- 6 Clean only with dry cloth.
- 7 Do not block any ventilation openings. Install in accordance with the manufacturer's instructions.
- 8 Do not install near any heat sources such as radiators, heat registers, stoves, or other apparatus (including amplifiers) that produce heat.
- 9 Do not defeat the safety purpose of the polarized or grounding-type plug. A polarized plug has two blades with one wider than the other. A grounding type plug has two blades and a third grounding prong. The wide blade or the third prong are provided for your safety. If the provided plug does not fit into your outlet, consult an electrician for replacement of the obsolete outlet.
- 10 Protect the power cord from being walked on or pinched particularly at plugs, convenience receptacles, and the point where they exit from the apparatus.
- 11 Only use attachments/accessories specified by the manufacturer.
- 12 Use only with the cart, stand, tripod, bracket, or table specified by the manufacturer, or sold with the apparatus. When a cart is used, use caution when moving the cart/apparatus combination to avoid injury from tip-over.



S3125A

- 13 Unplug this apparatus during lightning storms or when unused for long periods of time.
- 14 Refer all servicing to qualified service personnel. Servicing is required when the apparatus has been damaged in any way, such as power-supply cord or plug is damaged, liquid has been spilled or objects have fallen into the apparatus, the apparatus has been exposed to rain or moisture, does not operate normally, or has been dropped.
- 15 The *wall plug* is the disconnecting device. The plug must remain readily operable.
- 16 Remote control batteries should not be exposed to excessive heat such as sunshine, fire, or the like.
- 17 The apparatus should not be exposed to dripping or splashing, and no objects filled with liquids, such as vases, should be placed on the apparatus.
- 18 Your TV has four VESA mounting holes on the back. If you attach a wall-mount bracket or TV stand to the back of your TV, **the bracket or stand must be securely attached using all four holes**. If you do not use all four mounting holes, your TV may fall and cause property damage or personal injury. See the documentation that came with your wall mount or TV stand for complete mounting instructions.

### WARNING

#### Electric shock hazard

To reduce the risk of fire or electric shock, do not remove any cover or expose the device to rain or moisture. No user-serviceable parts are inside. Refer servicing to qualified service technicians.

#### Lightning

For added protection for your device receiver during a lightning storm, or when it is left unattended and unused for long periods of time, unplug it from the power outlet and disconnect any antenna or cable system. This helps prevent property damage and personal injury from lightning and power line surges.

#### Power lines

An outside antenna system should not be located in the vicinity of overhead power lines or other electric light or power circuits, or where it can fall into such power lines or circuits. When installing an outside antenna system, take extreme care to keep from touching such power lines or circuits as contact with them might be fatal.

#### Handling the LCD panel

- Your TV's screen is made of glass. Do not drop your TV or hit, jolt, or press hard against the LCD panel. If the screen breaks, be careful of broken glass.
- If the LCD panel is broken, make absolutely sure that you do not touch the liquid in the panel. This may cause skin inflammation.
- If the liquid gets in your mouth, immediately gargle, rinse, and consult with your doctor. Also, if the liquid gets in your eyes or touches your skin, consult with your doctor after rinsing for at least 15 minutes or longer in clean water.

## Replacement parts

When replacement parts are required, make sure that the service technician uses replacement parts specified by the manufacturer that have the same characteristics as the original part. Unauthorized substitutions may result in fire, electric shock, personal injury, or other hazards.

## Safety check

After completing any service or repair to this device, ask the service technician to perform routine safety checks to determine that your TV is in correct operating condition.

## Power source

Operate your TV only from the type of power source indicated on the marking label. If you are not sure of the type of power supplied to your home, consult an electrician or your local power company.

## Servicing

These servicing instructions are for use by qualified service personnel only. To reduce the risk of electric shock, do not perform any servicing other than that contained in the operating instructions unless you are qualified to do so.

## CAUTION

### Damage requiring service

Unplug this TV from the power outlet and refer servicing to qualified service personnel under the following conditions:

- When the power supply cord or plug is damaged or frayed.
- If liquid has been spilled or objects have fallen into your TV.
- If your TV has been exposed to rain or water.
- If your TV does not operate normally by following the operating instructions. Adjust only those controls covered by the operating instructions because incorrect adjustment of other controls may result in damage and will often require extensive work by a qualified technician to restore your TV to its normal operation.
- If your TV has been dropped or damaged in any way.
- When your TV exhibits a distinct change in performance.

### Outdoor antenna grounding

If an outside antenna or cable system is connected to your TV, make sure that the antenna or cable system is grounded to provide some protection against voltage surges and built-up static charges. Article 810 of the National Electrical Code, ANSI/NFPA No. 70, provides information with respect to correct grounding of the mast and supporting structure, grounding of the lead-in wire to an antenna discharge unit, size of grounding conductors, location of the antenna-discharge unit, connection to grounding electrodes, and requirements for the grounding electrode.

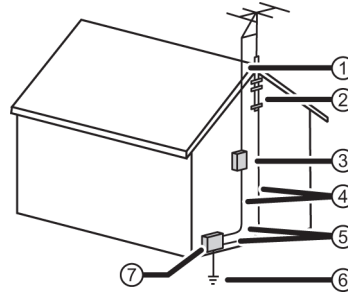

- 1 Antenna lead-in wire
- 2 Grounding clamp
- 3 Antenna discharge unit
- 4 Grounding conductors
- 5 Ground clamps
- 6 Power service grounding electrode system
- 7 Electric service equipment

## Note to CATV system installer

Article 820 of the National Electrical Code, ANSI/NFPA No. 40 provides guidance for correct grounding. Specifically, it states that the cable ground must be connected to the grounding system of the building as close to the point of cable entry as practical.

## Condensation

Moisture will form on the TV if the TV is brought from cool surroundings into a warm room or if the temperature of the room rises suddenly. When this happens, the TV's performance may be impaired. To prevent this, let the TV stand in its new surroundings for about an hour before switching it on, or make sure that the room temperature rises gradually.

Condensation may also form during the summer if the TV is exposed to the breeze from an air conditioner. In such cases, change the location of the TV.

## Mobile telephone warning

To avoid interference with your TV picture and sound, operating problems, or even damage, keep your cordless and cellular telephones away from the TV.

## End of life directives

Your TV may contain materials that are regulated for environmental reasons. Your TV also contains materials that can be recycled and reused. To help protect the environment, contact your local authorities for information about disposal or recycling and about finding a recycler in your area before you dispose of your TV.

## Non-active pixels

The LCD panel contains almost 3 million thin film transistors, which provide exceptionally sharp video quality. Occasionally, a few non-active pixels may appear on the screen as a fixed blue, green, or red point. These non-active pixels do not adversely affect the performance of your TV, and are not considered defects.

# 32" HD LED 720p/40" Full HD LED 1080p Sharp Roku TV

---

## Welcome

Congratulations on the purchase of your new TV! Discover the joy of endless entertainment. After it's set up, you'll be able to access a world of streaming content channels that may include Netflix, YouTube, Crackle, CNET, and literally thousands more.

### Important

Your TV receives automatic updates from time to time, enabling new content and features. For more information about your TV, go to:  
<https://go.roku.com/tvmanual>

## The new standard in Smart TVs

Welcome to TV like you've most likely never seen before—a home screen that you can personalize with your favorite devices and streaming channels. Choose from hundreds of thousands of streaming movies and TV episodes, plus music, sports, kids, family, international, and much more. You should never run out of things to watch.

### Note

A paid subscription or other payments may be required for some channels. Channel availability is subject to change and varies by country. Not all content is available in countries or regions where Roku products are sold.

## Get the most out of your new TV

Follow these simple steps to get the most out of your new TV.

- 1 Connect to the internet
  - It's simple, it's easy, and it will unlock a world of entertainment. All you need is a network connection. There are hundreds of free streaming channels, paid subscriptions services like Netflix and Spotify, convenient ways to rent or buy a favorite film or show with Google Play and Cineplex, and more.
- 2 Pick your favorite streaming channels
  - Find the entertainment you love. From the latest blockbuster movies to your favorite TV shows, with tons of live sports, a broad selection of music streaming channels, popular programming in a dozen international languages, 24x7 live news, and so much more, your new TV has your sweet spot. A paid subscription or other payments may be required for some channels.
- 3 Personalize your **Home** screen
  - Put your favorite broadcast TV, streaming channels, gaming console, and other devices front-and-center on the **Home** screen. No more flipping through inputs or wading through complicated menus. You can even personalize the names of each input and move tiles around so your most-often used devices and streaming channels are only a click away.
- 4 Search for your favorite movie, TV show, actor, or director
  - After you're connected to the internet, you can easily search across top streaming channels by movie or TV show title, actor, or director—all from one place. Search results are organized by price so you can always see the best priced option. A paid subscription or other payments may be required for some channels.
- 5 Pause live TV
  - Pause, resume, fast forward, and rewind TV shows. Simply connect your own USB drive with 16GB or bigger capacity to the TV and pause live TV for up to 90 minutes.

### Note

Live TV Pause is available on digital TV shows received on the TV's antenna input only, and only when the TV is linked to a valid Roku account.



## 6 Send your personal media to the big screen

- Send personal photos, videos, and music from your compatible smartphone or tablet to the TV screen in just a few taps. Plus, with certain channels, such as Netflix and YouTube, send movies, shows, sport highlights, and more directly to your TV.

### Note

The Roku app for Microsoft Windows devices does not cast videos.

## 7 Follow movies coming soon

- Use My Feed to choose from and follow a list of upcoming movies, and then watch for alerts each time one of your followed movies becomes available or changes price.

### Note

My Feed is not available in the Roku App for Windows devices in the United States or Canada.

## 8 Take charge with a smartphone or tablet

- Control your TV with the included remote or from your compatible smartphone or a tablet with the free mobile app for iOS®, Android™, and Windows™ mobile devices. Browse channels, view My Feed, listen to audio from streaming programs, and even search with voice via the free mobile app.

### Note

Voice search, Mobile listening, and My Feed are not available in the Roku app for Windows devices.

- Mirror your compatible smartphone or tablet on your TV. Share videos, photos, web pages, and more from compatible devices.
- Use your compatible smartphone or tablet to connect your TV to the types of networks found in hotels and college dorms, where you may have to agree to terms, enter codes, or provide identifying information.

### Note

Using your Roku TV on a restricted public network requires wireless availability and use of your network-connected smartphone, tablet, or computer to authenticate access to your account. Your TV must already be linked to your Roku account and activated. Also, you must use your Roku TV remote control, because the Remote feature of the Roku mobile app does not work on restricted public networks. Streaming content might be limited due to your geographic location or because of restrictions imposed by the wireless network host.

Many features work with top mobile devices. Go to <http://support.roku.com> for device compatibility information. Let's get started.

## Accessibility (U.S. models only)

Your TV provides audio descriptions of menus and some remote control functions. Depending on the broadcaster, audio narration of key elements in programs may also be available.

Visit <http://go.roku.com/tvmanual> for more information or contact us at 1-855-544-2030.



## Installing the stands or wall-mount bracket

- If you want to place your TV on a table or in an entertainment center, go to [Installing the stands](#).
- If you want to mount your TV on a wall, go to [Installing a wall-mount bracket](#).

### Notes

- If you plan to wall-mount your TV, do not install the stands.
- Store the stands and stand screws in case you decide to use the stands in the future.

### Installing the stands

- 1 Carefully place your TV face-down on a cushioned, clean surface to protect the screen.

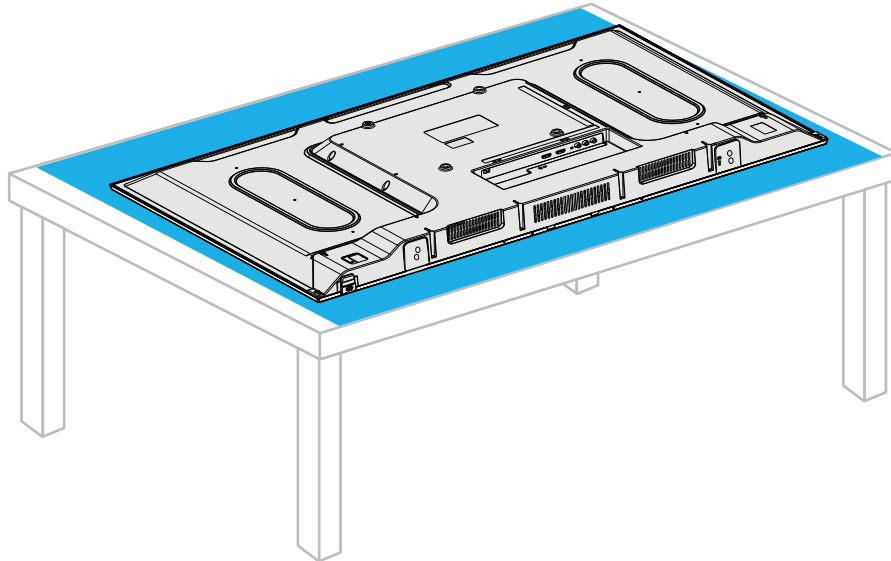

40" TV shown

- 2 Align the TV stands with the screw holes on the bottom of the TV. Make sure that the arrows on the stands are pointing towards the front of the TV. Secure the stands to the TV with the four provided screws.

| Model | Screw type | Screw length | # of screws |
|-------|------------|--------------|-------------|
| 32"   | M4         | 10 mm        | 4           |
| 40"   | M4         | 20 mm        | 4           |

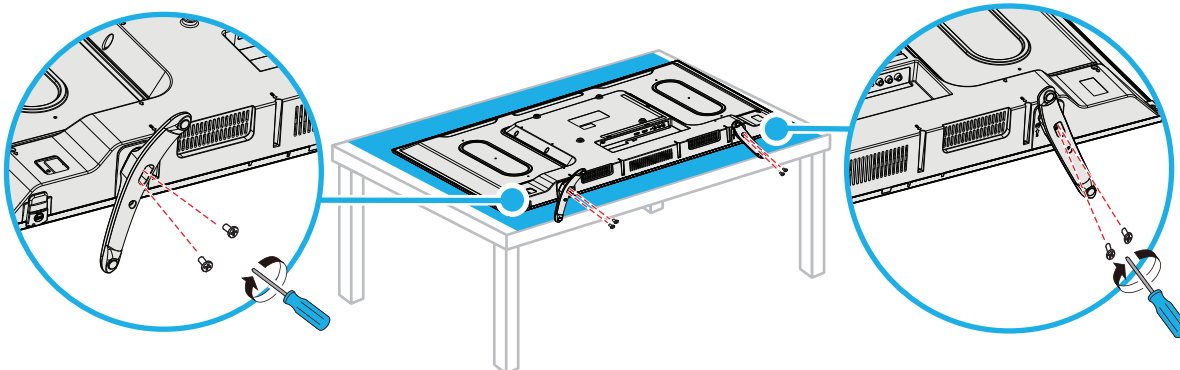

40" TV shown

## Installing a wall-mount bracket

### Warnings

- Your TV has four VESA mounting holes on the back. If you attach a wall-mount bracket to the back of your TV, **the bracket must be securely attached, using all four holes.** If you do not use all four mounting holes, your TV may fall and cause property damage or personal injury. See the documentation that came with your wall mount for complete mounting instructions.
- Your TV is intended to be supported by a UL Listed wall mount bracket with suitable weight/load. (See [Miscellaneous](#) on page 43.)

- 1 Carefully place your TV face-down on a cushioned, clean surface to protect the screen.

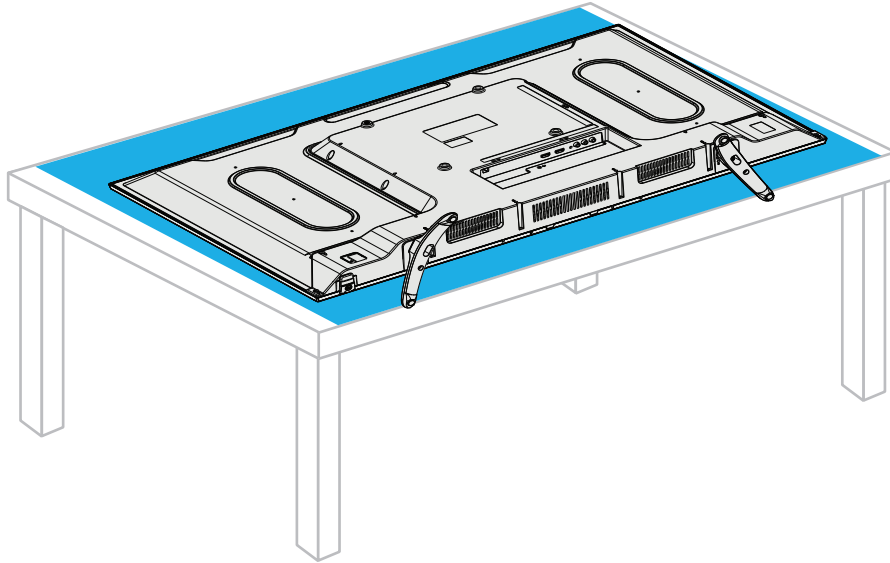

40" TV shown

- 2 If the TV stands are installed, remove the four screws that secure the stands to your TV.

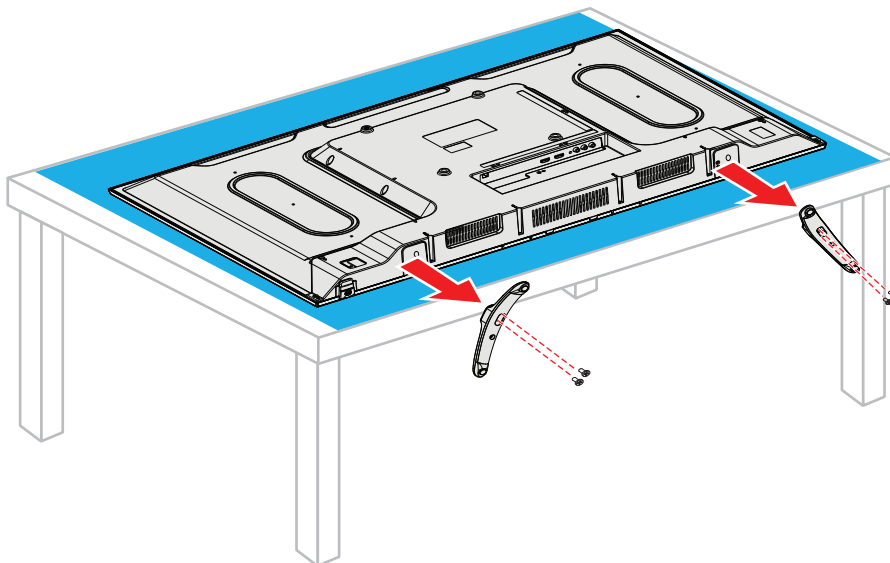

40" TV shown

- 3 Attach the wall-mount bracket to your TV using the mounting holes on the back of your TV. See the instructions that came with the wall-mount bracket for information about how to correctly hang your TV.

### Notes

- The length of the wall-mount screws vary depending on the wall-mount bracket you purchased. See the instructions that came with the wall-mount bracket for screw lengths.
- The mounting holes on the back of your TV take type M6 screws (10 mm).

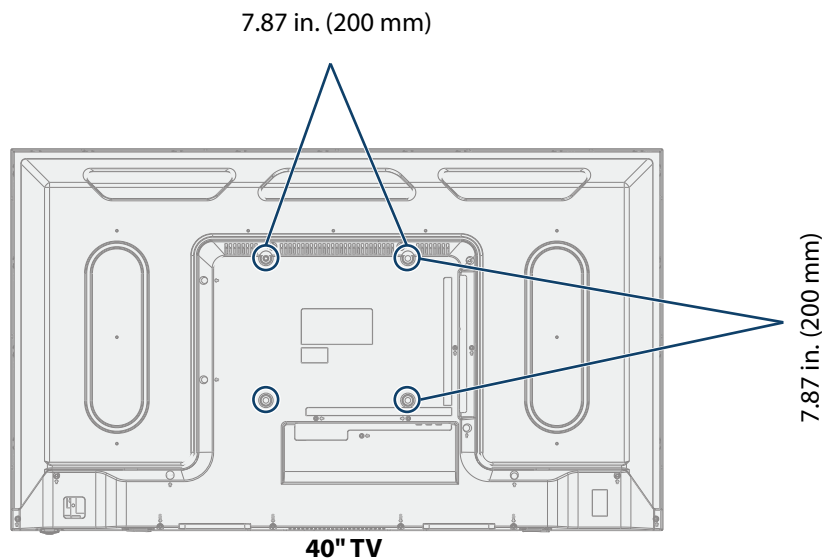
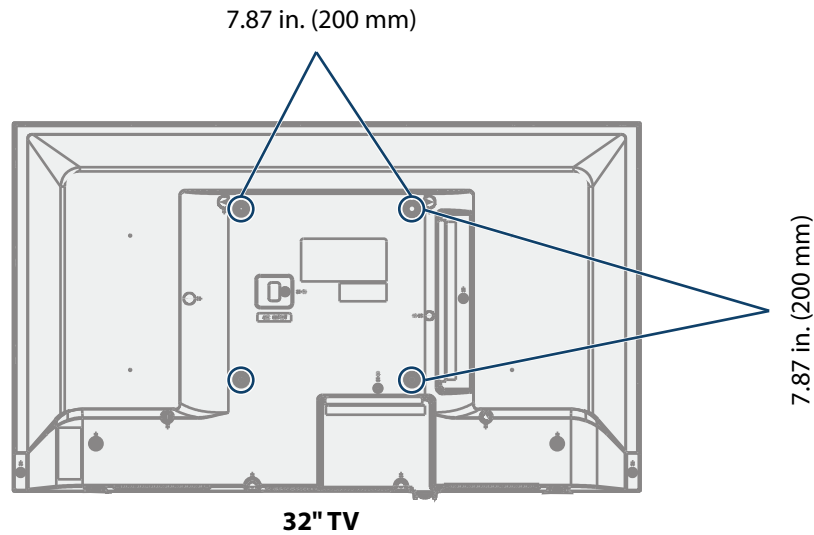

# SHARP • Roku TV

## TV components

Your TV has built-in controls for adjusting basic settings and several sets of jacks for connecting devices to your TV.

This section contains information about:

- [Package contents](#)
- [Front features](#)
- [Side jacks](#)
- [Back jacks](#)
- [Remote control](#)

### Package contents

- 32" or 40" LED Sharp Roku TV
- Remote control and batteries (2 AAA)
- TV stands (2)
- Screws (4)
- Power cord (32" TV)
- *Quick Setup Guide*
- *Important Information*
- *Roku TV End User License Agreement (EULA)*

LC-32LB601U/LC-32LB601C/LC-40LB601U  
32" HD LED 720p/40" Full HD LED 1080p Sharp Roku TV

### Front features

Besides the viewing screen, the front has a remote control sensor, to receive the signals from the remote control (do not block), and a status indicator.

The status indicator lights red when your TV is off, turns off when your TV is on, or blinks when receiving commands from the remote control.

## Side jacks

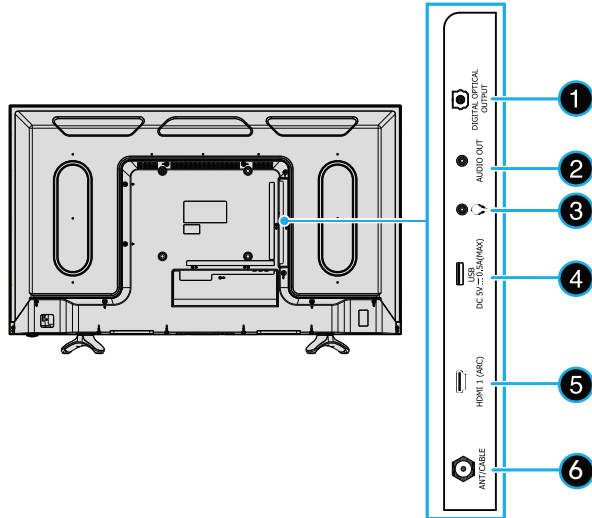

## Back jacks

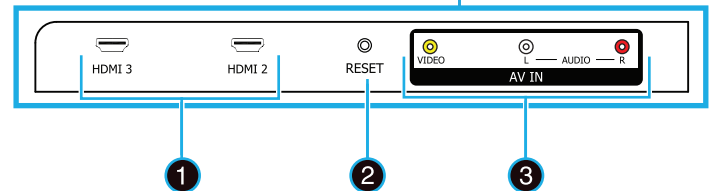
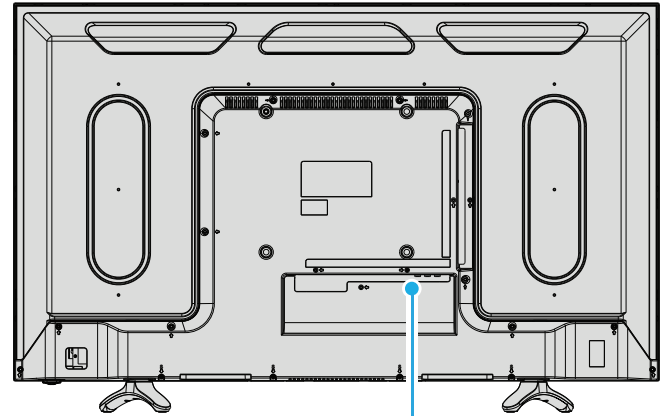

| # | Item                   | Description   |
|---|------------------------|---|
| 1 | DIGITAL OPTICAL OUTPUT | Connect a digital sound bar, speaker system, or home theater system to this jack to listen to TV audio through external speakers. For more information, see <a href="#">Digital audio using the DIGITAL OPTICAL OUTPUT jack</a> on page 28.   |
| 2 | AUDIO OUT              | Connect an analog sound bar, speaker system, or home theater system to this jack to listen to TV audio through external speakers. For more information, see <a href="#">Analog audio using the AUDIO OUT jack</a> on page 30.   |
| 3 | (headphones)           | Connect headphones to this jack. See <a href="#">Connecting headphones</a> on page 27.  |
| 4 | USB                    | Connect a USB flash drive to this jack to view compatible photos and video, listen to music files, or pause live TV. For more information, see <a href="#">Connecting a USB flash drive</a> on page 26 and <a href="#">Pause live TV</a> on page 7.   |
| 5 | HDMI 1 (ARC)           | Connect HDMI® devices to this jack. For more information, see <a href="#">HDMI® (best)</a> on pages 17, 21, or 23 or <a href="#">Connecting a computer</a> on page 25. Connect an ARC-enabled home theater receiver to this jack. For more information, see <a href="#">Digital audio using the HDMI 1 (ARC) jack</a> on page 29. |
| 6 | ANT/CABLE              | Connect an antenna or cable TV to this jack. For more information, see <a href="#">Coaxial (good)</a> on page 19 or <a href="#">Connecting an antenna or cable TV (no box)</a> on page 20.  |



| # | Item                 | Description  |
|---|----------------------|--|
| 1 | HDMI 2/HDMI 3        | Connect HDMI® devices to these jacks. For more information, see <a href="#">HDMI® (best)</a> on pages 17, 21, or 23 or <a href="#">Connecting a computer</a> on page 25. |
| 2 | RESET                | Press and hold reset for 15 seconds for factory reset.   |
| 3 | VIDEO/ L and R AUDIO | Connect an AV device to these jacks. For more information, see <a href="#">AV (good)</a> on page 18, 22, or 24.  |

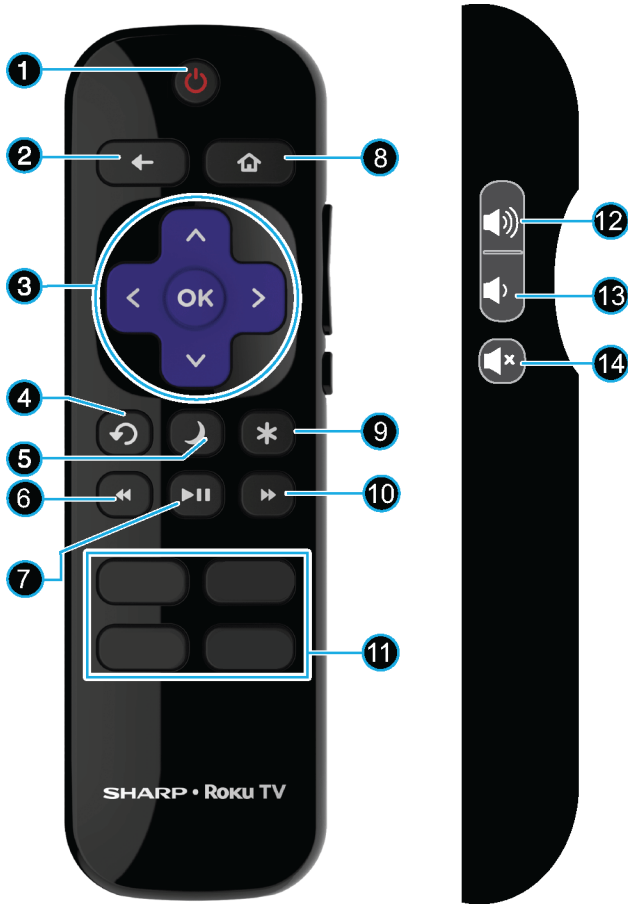



## Remote control



| # | Button    | Description   |
|---|-----------|---|
| 1 | ⏻ (power) | Turns your TV on or off.  |
| 2 | ← (back)  | The action depends on what you are doing with your TV:<br><b>Menu</b> —Goes back to the previous menu or screen.<br><b>Home screen tile</b> —Moves the highlight back to the <b>Home</b> menu option.<br><b>Watching Antenna TV or a TV input</b> —Returns to the screen from which the input was selected.<br><b>Playing streaming content</b> —Stops playing stream and returns to the previous menu or screen.<br><b>Browsing streaming content</b> —Goes to the previous level in the content tree. |

| #  | Button               | Description  |
|----|----------------------|--|
| 3  | ^ / v / < / > and OK | ^ / v—Moves the highlight up or down one item.<br><—Moves the highlight left, if a < hint appears. <ul style="list-style-type: none"> <li>• When watching TV, displays your channel list.</li> <li>• When playing most streaming videos, skips backward in the video.</li> </ul> >—Moves the highlight to the right, if a > hint appears. <ul style="list-style-type: none"> <li>• When watching TV with the channel list displayed, dismisses the channel list.</li> <li>• When playing most streaming videos, skips forward in the video.</li> </ul> <b>OK</b> —Selects the highlighted option. <ul style="list-style-type: none"> <li>• When watching TV, displays information for the current TV program.</li> </ul> |
| 4  | ↶ (previous)         | <b>Watching Antenna TV or cable (no set-top box)</b> —Changes to the previous channel.<br><b>Playing streaming content</b> —Jumps back one position in the video.<br><b>Menu</b> —Backspaces one letter during menu entries, such as Search.   |
| 5  | ☾ (sleep)            | First press displays a banner showing the remaining sleep time, if any, or <b>Sleep timer is off</b> . Subsequent presses cycle among the preset sleep time intervals: <b>30 minutes, 1 hour, 1.5 hours, 2 hours, and 3 hours</b> . After it is set, the Sleep timer remains in effect regardless of what you are watching.  |
| 6  | ⏮ (rewind)           | When playing streaming video that supports this feature or broadcast TV if Live TV Pause is enabled, cycles through 1×, 2×, and 3× rewind speeds.<br>When playing streaming audio, jumps to the previous track/selection.<br>When any menu, tile, or channel in the channel list is highlighted, jumps up one page.<br>When using a virtual keyboard, jumps to the character at the top of the current column.   |
| 7  | ⏸ (play/pause)       | Pauses and plays streaming content.  |
| 8  | 🏠 (home)             | Immediately returns to the <b>Home</b> screen and stops playback if you are watching TV or streaming content.  |
| 9  | * (options)          | Displays an <b>Options</b> menu, but only when the <b>Options *</b> hint in the upper right corner of the screen is not dimmed. The menu you see varies depending on what you are doing with your TV.<br>Also, in most cases, pressing * while video is playing displays an <b>Options</b> menu over part of the screen where you can adjust various picture and sound settings.   |
| 10 | ⏭ (fast forward)     | When playing streaming video that supports this feature or broadcast TV if Live TV Pause is enabled, cycles through 1×, 2×, and 3× fast-forward speeds.<br>When playing streaming audio, jumps to the next track/selection.<br>When any menu, tile, or channel in the channel list is highlighted, jumps down one page.<br>When using a virtual keyboard, jumps to the character at the bottom of the current column.  |

| #  | Button  | Description   |
|----|---|---|
| 11 | Streaming Channels Shortcuts  | <p>Dedicated buttons show the logo of a featured streaming content provider. Pressing a button turns your TV on (if your TV is not already on), and if your TV is operating and is connected to the internet, performs one of the following actions:</p> <ul style="list-style-type: none"> <li>• Displays the streaming channel's main page if you have already added the channel to your <b>Home</b> screen.</li> <li>• Displays the streaming channel's sign-up page if you have not already added the channel so that you can agree to any terms and fees for the service.</li> </ul> |
| 12 |  (volume up) | <p>Turns the volume up one setting with each press. Press and hold to turn the volume up rapidly. A volume indicator shows the volume level while you are adjusting the volume and for a few seconds afterward.</p> <p><b>Note:</b> If your TV is muted, pressing  unmutes the sound.</p>  |

| #  | Button  | Description  |
|----|---|--|
| 13 |  (volume down) | <p>Turns the volume down one setting with each press. Press and hold to turn the volume down rapidly. A volume indicator shows the volume level while you are adjusting the volume and for a few seconds afterward.</p> <p><b>Note:</b> If your TV is muted, pressing  does not unmute the sound.</p> |
| 14 |  (mute)        | <p>Mutes and unmutes the TV sound. A volume indicator shows the current volume level and a mute icon when you press  and for a few seconds afterward. If <b>Closed captioning</b> is set to <b>When Mute</b>, captions are displayed while your TV is muted.</p>                                      |





## What connection should I use?

Your TV has several connection types for connecting devices to your TV.

For the best video quality, you should connect a device to the best available connection.

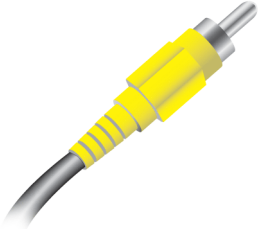
Use the following tables to identify cables:

| Video quality                              | Connection type and jack                            | Cable connector   |
|--|---|---|
| Best (use this if your devices have HDMI®) | HDMI® video/audio                                   |    |
| Good                                       | AV (composite video) (requires an audio connection) |   |
| Good                                       | Coaxial video/audio                                 |  |

| Connection type and jack | Cable connector |
|--------------------------|-----------------|
|--------------------------|-----------------|

Digital optical audio output



Analog audio input

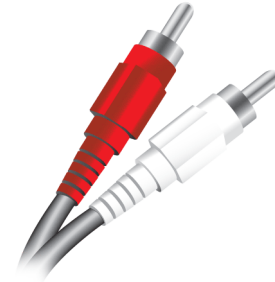

3.5mm analog audio output



### Cautions

- Check the jacks for position and type before making any connections.
- Loose connections can cause poor audio or video quality. Make sure that all connections are tight and secure.
- The external audio/video devices shown may be different from your devices. If you have questions, refer to the documentation that came with your devices.
- Always turn off your TV when connecting external devices.

# Connecting a cable or satellite box

Many cable or satellite TV boxes have more than one connection type. To get the best video, you should use the best connection type available. For more information, see [What connection should I use?](#) on page 16.

You can connect your cable or satellite box using:

- **HDMI® (best)**
- AV (good)
- Coaxial (good)

## HDMI® (best)

**Note**

For better picture quality, we recommend that you use cables designated as High Speed HDMI® cables.

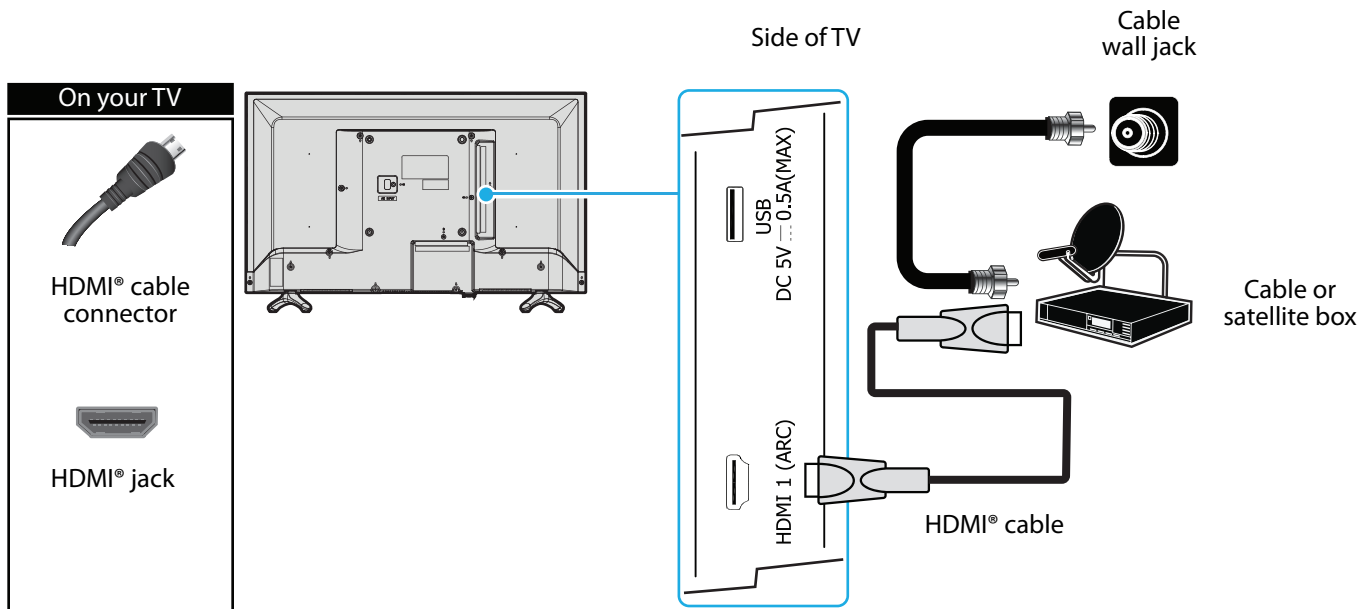

40" TV shown

- 1 Make sure that your TV's power cord is unplugged and all connected devices are turned off.
- 2 Connect the incoming cable from the cable wall jack to the cable-in jack on the cable or satellite box.
- 3 Connect an HDMI® cable (not provided) to an **HDMI** jack on your TV and to the **HDMI OUT** jack on the cable or satellite box.
- 4 Plug your TV's power cord into a power outlet, turn on your TV, then turn on the cable or satellite box.
- 5 On the **Home** screen, press **^** **v** **<** or **>** to highlight the **HDMI 1**, **HDMI 2**, or **HDMI 3** tile, then press **OK**.

**Note**

An HDMI® cable carries both audio and video. You do not need to use any audio cables.

## AV (good)

### Notes

Cables are often color-coded to match color-coded jacks.

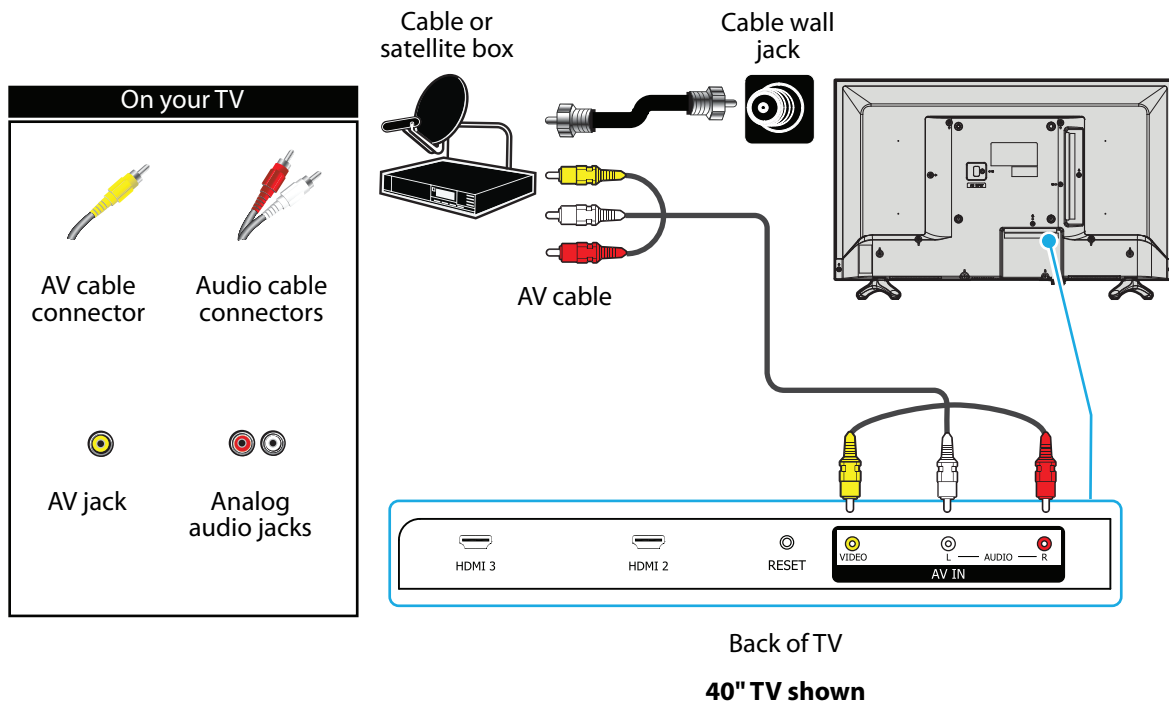

Back of TV  
40" TV shown

- 1 Make sure that your TV's power cord is unplugged and all connected devices are turned off.
- 2 Connect the incoming cable from the cable wall jack to the cable-in jack on the cable or satellite box.
- 3 Connect an AV cable (not provided) to the **VIDEO** jack and **L** and **R AUDIO** jacks on your TV and to the AV and audio out jacks on the cable or satellite box.

### Note

When you connect the audio using the **L** and **R AUDIO** jacks, the audio output is analog.

- 4 Plug your TV's power cord into a power outlet, turn on your TV, then turn on the cable or satellite box.
- 5 On the **Home** screen, press **^** **v** **<** or **>** to highlight the **AV** tile, then press **OK**.

## Coaxial (good)

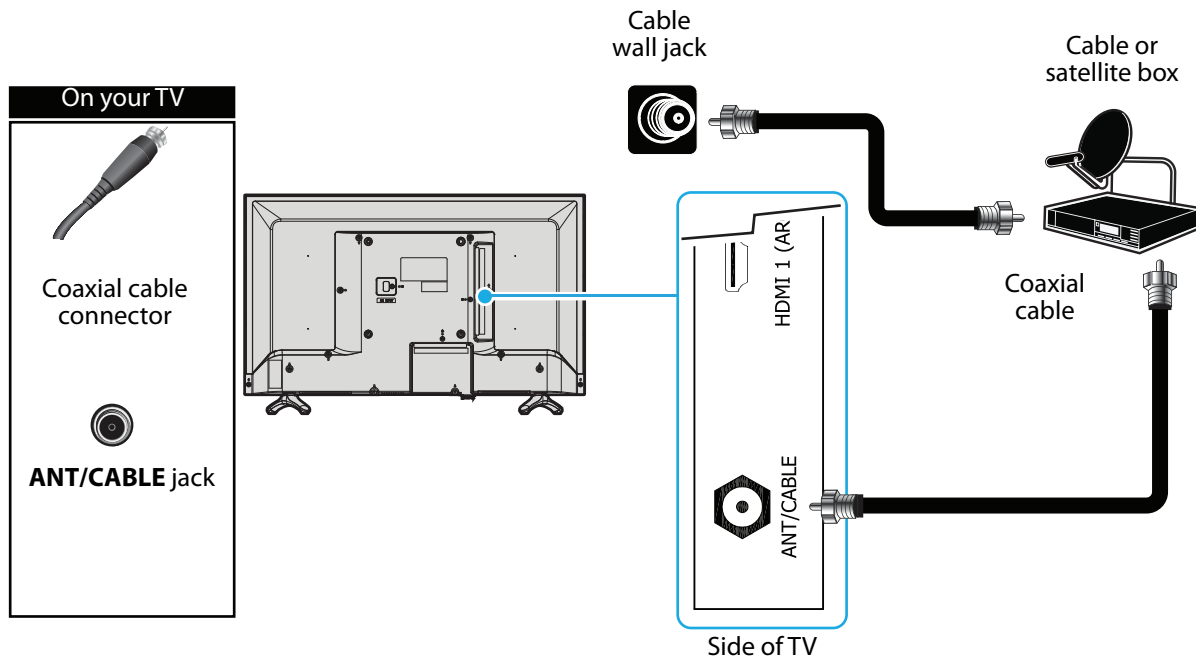

40" TV shown

- 1 Make sure that your TV's power cord is unplugged and all connected devices are turned off.
- 2 Connect the incoming cable from the cable wall jack to the cable-in jack on the cable or satellite box.
- 3 Connect a coaxial cable (not provided) to the **ANT/CABLE** jack on your TV and to the coaxial out jack on the cable or satellite box.
- 4 Plug your TV's power cord into a power outlet, turn on your TV, then turn on the cable or satellite box.
- 5 On the **Home** screen, press **^** **v** **<** or **>** to highlight the **Antenna TV** tile, then press **OK**. If you have not set up the TV tuner, follow the on-screen instructions.

### Notes

- Use a coaxial cable to eliminate interference and noise from radio waves.
- Do not bundle the coaxial cable with the power cord or other cables.

# Connecting an antenna or cable TV (no box)

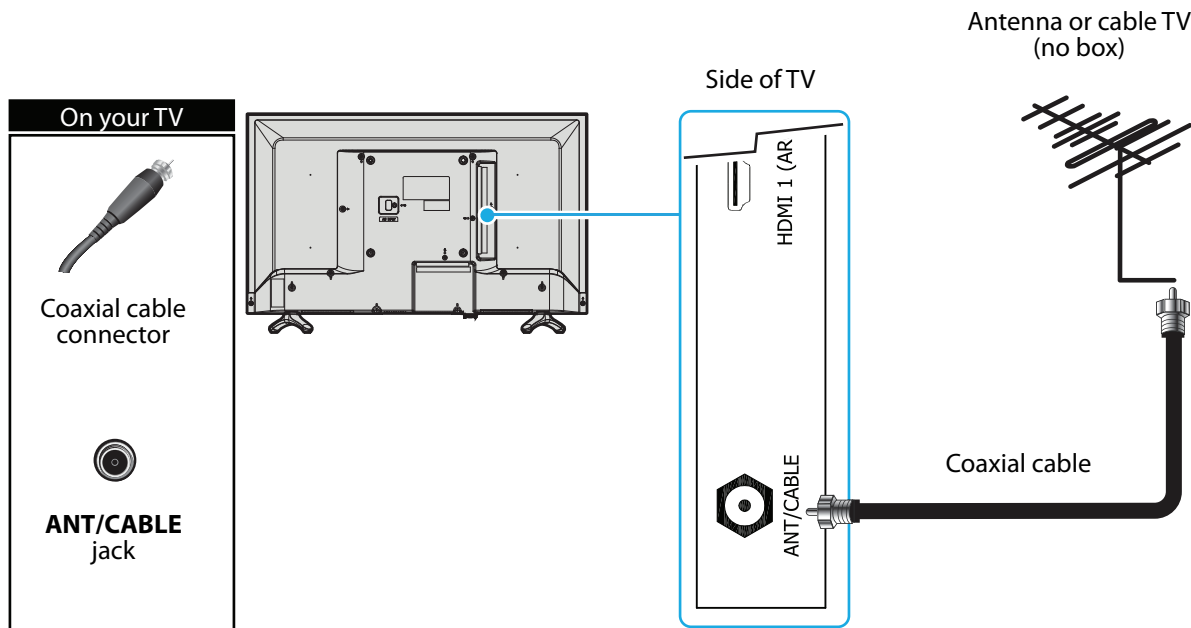

40" TV shown

- 1 Make sure that your TV's power cord is unplugged and all connected devices are turned off.
- 2 Connect a coaxial cable (not provided) to the **ANT/CABLE** jack on your TV and to the antenna or cable TV wall jack.
- 3 Plug your TV's power cord into a power outlet, then turn on your TV.
- 4 On the **Home** screen, press **^** **v** **<** or **>** to highlight the **Antenna TV** tile, then press **OK**. If you have not set up the TV tuner, follow the on-screen instructions.

**Notes**

- Use a coaxial cable to eliminate interference and noise from radio waves.
- Do not bundle the coaxial cable with the power cord or other cables.
- If the antenna is not installed correctly, contact qualified service personnel to correct the problem.
- If the signal level for a channel is weak, the picture may be distorted. Adjust the antenna or use a highly directional outdoor or set-top antenna with a built-in amplifier.
- If the picture quality is good on some channels and poor on others, the problem may be caused by a poor or weak signal from the broadcaster or cable TV provider.
- If you connect to cable TV without a set-top box and experience poor picture quality, you may need to install a set-top box to improve signal reception and picture quality. Contact your cable TV provider about upgrading to a set-top box.
- Many high-definition (HD) channels upscale standard-definition (SD) content. The picture displayed on your TV is still displayed as SD, thus the picture quality will not be as clear or crisp as it would be if the content was originally recorded in HD.

# Connecting a DVD or Blu-ray player

Many DVD or Blu-ray players have more than one connection type. To get the best video, you should use the best connection type available. For more information, see [What connection should I use?](#) on page 16.

You can connect a DVD or Blu-ray player using:

- **HDMI® (best)**
- **AV (good)**

## HDMI® (best)

**Note**  
For better picture quality, we recommend that you use cables designated as High Speed HDMI® cables.

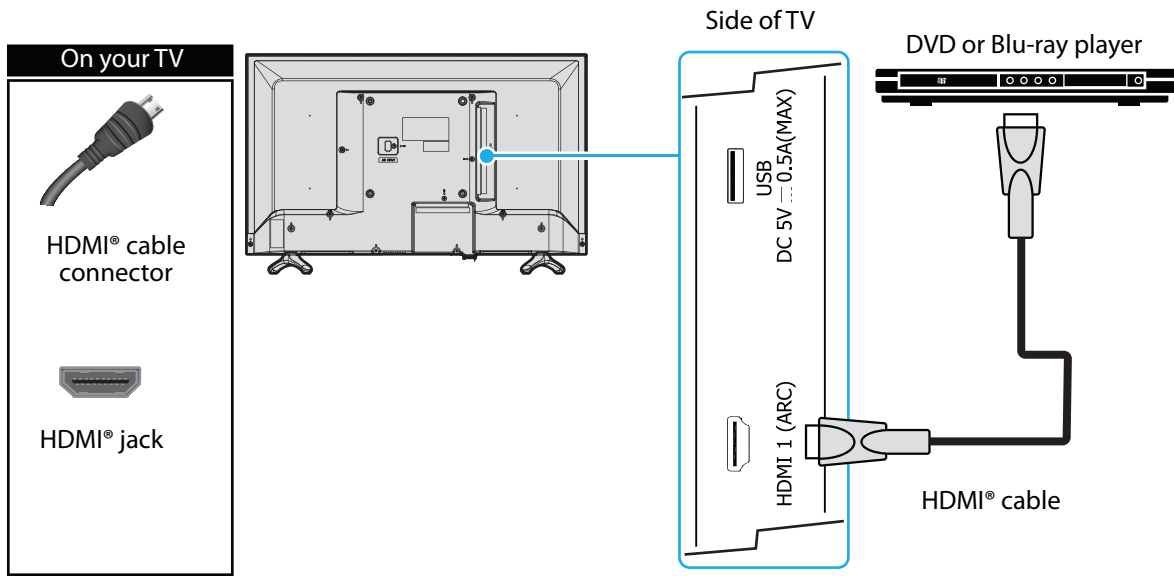

40" TV shown

- 1 Make sure that your TV's power cord is unplugged and the DVD or Blu-ray player is turned off.
- 2 Connect an HDMI® cable (not provided) to an **HDMI** jack on your TV and to the **HDMI OUT** jack on the DVD or Blu-ray player.
- 3 Plug your TV's power cord into a power outlet, then turn on your TV and DVD or Blu-ray player.
- 4 On the **Home** screen, press **^** **v** **<** or **>** to highlight the **HDMI 1**, **HDMI 2**, or **HDMI 3** tile, then press **OK**.

**Note**  
An HDMI® cable carries both audio and video. You do not need to use any audio cables.

## AV (good)

**Note**  
Cables are often color-coded to match color-coded jacks.

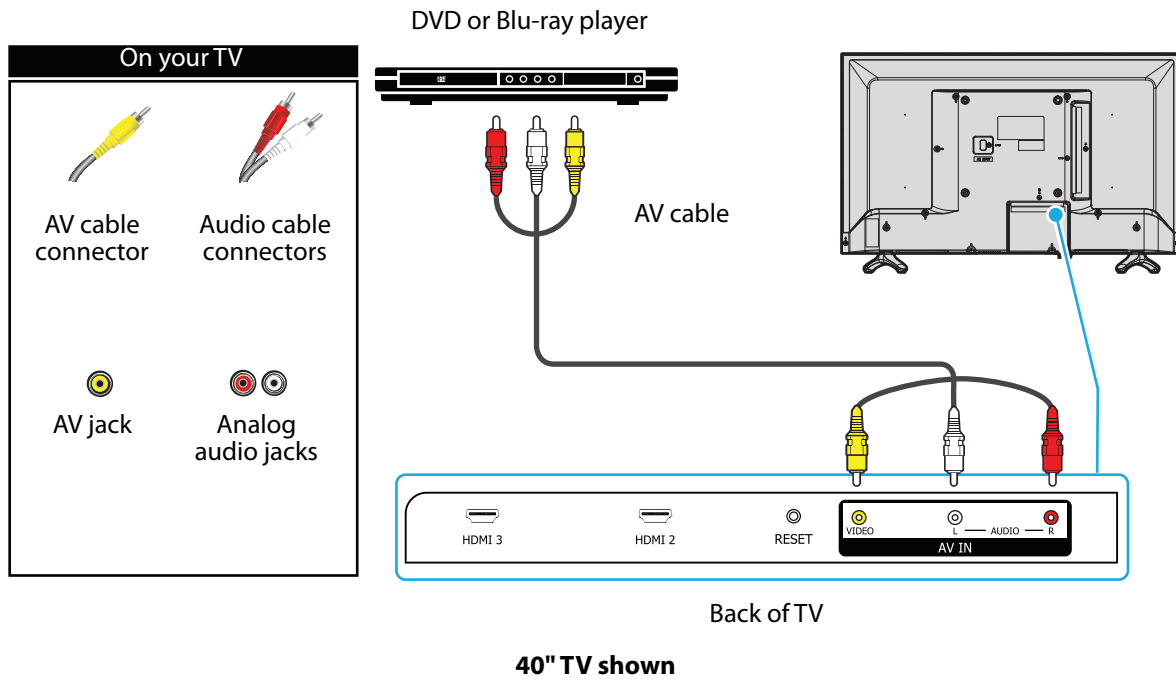

- 1 Make sure that your TV's power cord is unplugged and the DVD or Blu-ray player is turned off.
- 2 Connect an AV cable (not provided) to the **VIDEO** jack and **L** and **R AUDIO** jacks on your TV and to the **AV OUT** jacks on the DVD or Blu-ray player.

**Note**  
When you connect the audio using the **L** and **R AUDIO** jacks, the audio output is analog.

- 3 Plug your TV's power cord into a power outlet, then turn on your TV and DVD or Blu-ray player.
- 4 On the **Home** screen, press **^** **v** **<** or **>** to highlight the **AV** tile, then press **OK**.



# Connecting a game console

Many game consoles have more than one connection type. To get the best video, you should use the best connection type available. For more information, see [What connection should I use?](#) on page 16.

You can connect a game console using:

- **HDMI® (best)**
- AV (good)

## HDMI® (best)

**Note**  
For better picture quality, we recommend that you use cables designated as High Speed HDMI® cables.

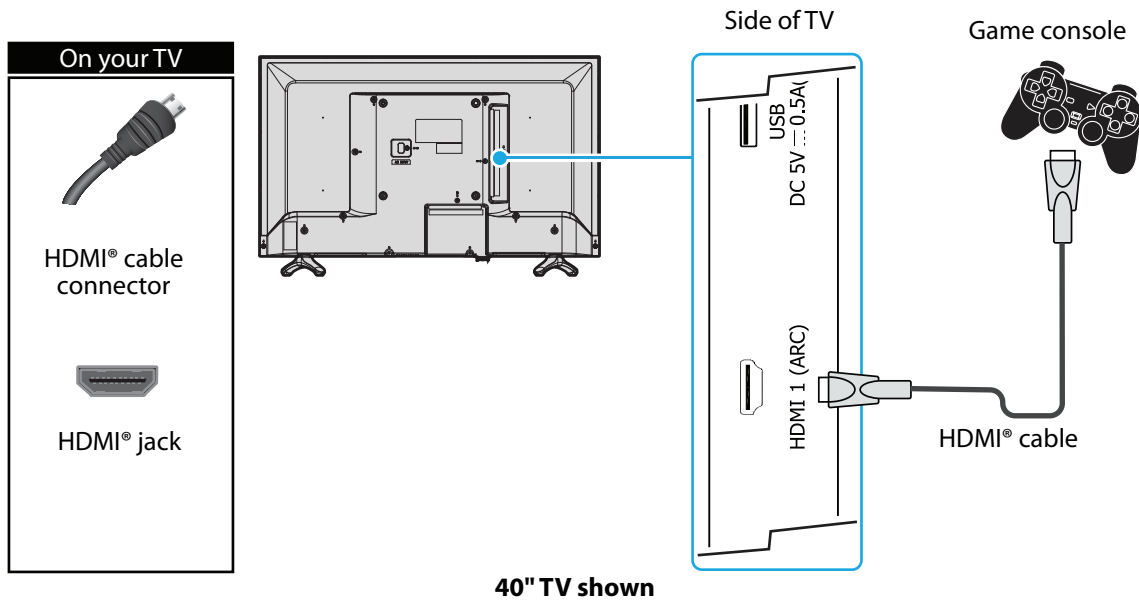

- 1 Make sure that your TV's power cord is unplugged and the game console is turned off.
- 2 Connect an HDMI® cable (not provided) to an **HDMI** jack on your TV and to the **HDMI OUT** jack on the game console.
- 3 Plug your TV's power cord into a power outlet, then turn on your TV and the game console.
- 4 On the **Home** screen, press **^** **v** **<** or **>** to highlight the **HDMI 1**, **HDMI 2**, or **HDMI 3** tile, then press **OK**.

**Note**  
An HDMI® cable carries both audio and video. You do not need to use any audio cables.

## AV (good)

### Note

Cables are often color-coded to match color-coded jacks.

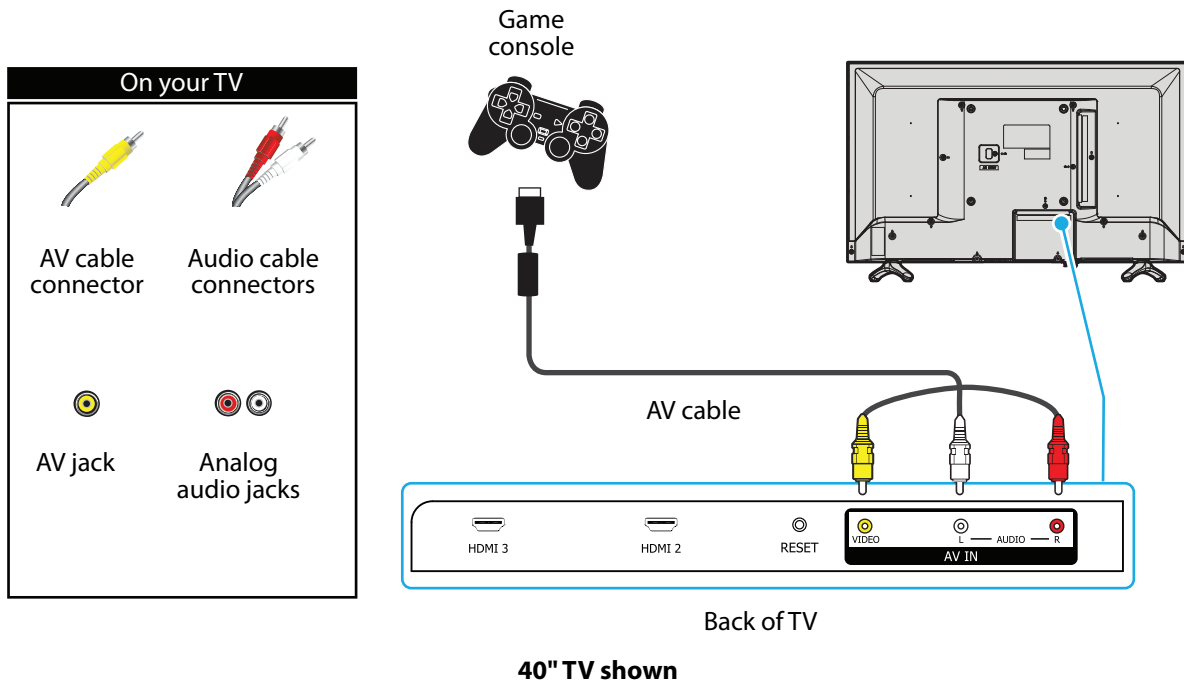

- 1 Make sure that your TV's power cord is unplugged and the game console is turned off.
- 2 Connect the game console's AV cable (not provided) to the **VIDEO** jack and **L** and **R AUDIO** jacks on your TV and to the AV jack(s) on the game console.

### Note

- Some older game consoles come with a special AV cable. See the documentation that came with your game console or check the manufacturer's website.
- When you connect the audio using the **L** and **R AUDIO** jacks, the audio output is analog.

- 3 Plug your TV's power cord into a power outlet, then turn on your TV and the game console.
- 4 On the **Home** screen, press **^** **v** **<** or **>** to highlight the **AV** tile, then press **OK**.

# SHARP • Roku TV

## Connecting a computer

LC-32LB601U/LC-32LB601C/LC-40LB601U  
32" HD LED 720p/40" Full HD LED 1080p Sharp Roku TV

You can use an HDMI® jack on your TV to connect to a computer.

### Note

For better picture quality, we recommend that you use cables designated as High Speed HDMI® cables.

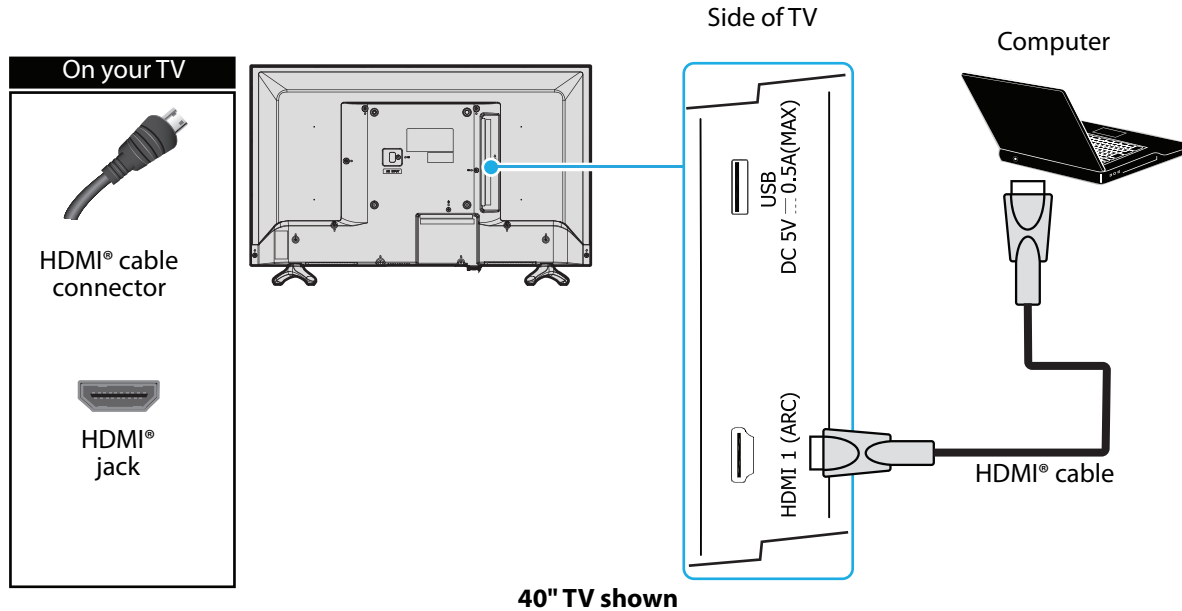

- 1 Make sure that your TV's power cord is unplugged and the computer is turned off.
- 2 Connect an HDMI® cable (not provided) to an **HDMI** jack on your TV and to the **HDMI OUT** jack on the computer.
- 3 Plug your TV's power cord into a power outlet, then turn on your TV and the computer.
- 4 On the **Home** screen, press **^** **v** **<** or **>** to highlight the **HDMI 1**, **HDMI 2**, or **HDMI 3** tile, then press **OK**.
- 5 Adjust the display properties on the computer, if necessary.

## Connecting a USB flash drive

When you connect a USB flash drive to the **USB** jack on your TV, you can view photos and videos or listen to music stored on the drive or you can use the **Live TV Pause** feature to pause live TV for up to 90 minutes.

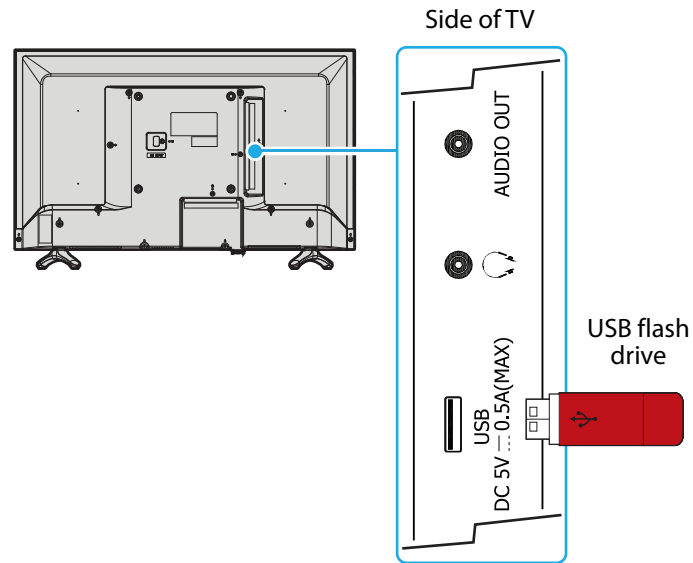

40" TV shown

- 1 Plug a USB flash drive into the **USB** port on your TV.

### Caution

Do not remove the USB flash drive or turn off your TV while using the USB flash drive. You may lose data or damage the USB flash drive.

- 2 Press **^** or **v** to highlight the **Roku Media Player** or **USB Media Player** tile, then press **OK**.

# SHARP • Roku TV

## Connecting headphones

LC-32LB601U/LC-32LB601C/LC-40LB601U  
32" HD LED 720p/40" Full HD LED 1080p Sharp Roku TV

When you connect headphones, your TV speakers are muted and sound only plays through the headphones.

### Warning

Loud noise can damage your hearing. When using headphones, use the lowest volume setting on your headphones that still lets you hear the sound.

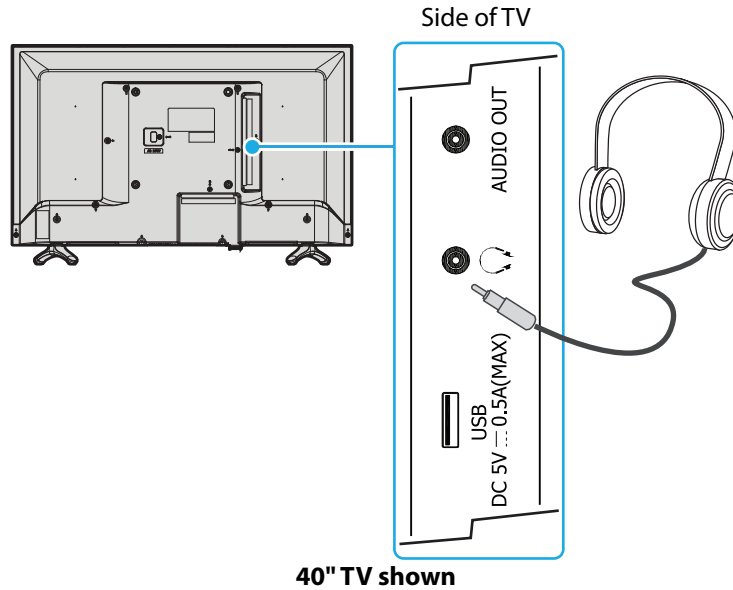

- Connect the headphones to the 🎧 jack on your TV.

### Note

You can also connect a home theater system, sound bar, or external speaker system to the 🎧 jack.

# Connecting external speakers or a sound bar

When you connect external speakers or a sound bar, sound plays through your TV speakers and the external speakers or sound bar.

You can connect external speakers or a sound bar using:

- Digital audio using the **DIGITAL OPTICAL OUTPUT** jack
- Digital audio using the **HDMI 1 (ARC)** jack
- Analog audio using the **AUDIO OUT** jack

## Digital audio using the DIGITAL OPTICAL OUTPUT jack

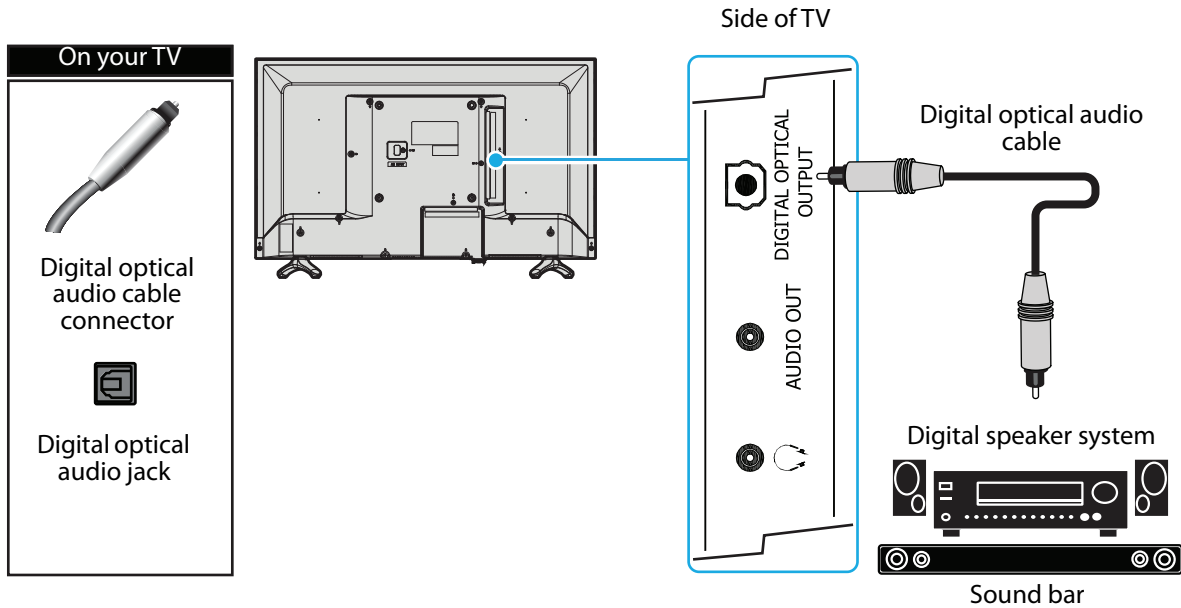

40" TV shown

- 1 Make sure that your TV's power cord is unplugged and the digital speaker system or sound bar is turned off.
- 2 Connect a digital optical audio cable (not provided) to the **DIGITAL OPTICAL OUTPUT** jack on your TV and to the digital optical **AUDIO IN** jack on the digital speaker system or sound bar.
- 3 Plug your TV's power cord into a power outlet, then turn on your TV.
- 4 Turn on the digital speaker system or sound bar, then set it to the correct source. For more information, see the documentation that came with the digital speaker system or sound bar.
- 5 To turn off your TV speakers, on the **Home** menu, press **^** or **v** to highlight **Settings**, then press **OK**. Highlight **Audio**, then press **OK**. Highlight **TV speakers**, then press **OK**. Press **OK** to remove the check from the **TV speakers enabled** check box.

## Digital audio using the HDMI 1 (ARC) jack

Your TV can send sound to an ARC device, like an AV receiver, to create a home theater that uses two or more speakers. When you connect external speakers or a sound bar, sound plays through your TV speakers and the external speakers or sound bar.

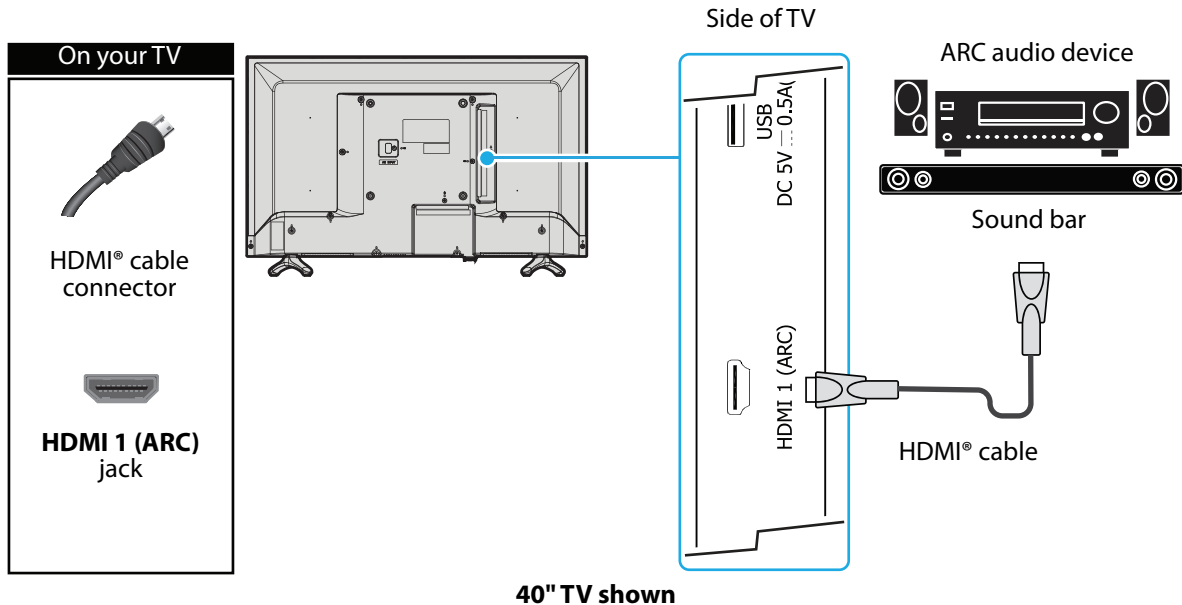

- 1 Make sure that your TV's power cord is unplugged and the digital speaker system or sound bar is turned off.
- 2 Connect an HDMI® cable (not provided) to the **HDMI 1 (ARC)** jack on your TV and to the **HDMI IN** jack on the digital speaker system or sound bar.
- 3 Plug your TV's power cord into a power outlet, then turn on your TV.
- 4 Turn on the digital speaker system or sound bar, then set it to the correct source. For more information, see the documentation that came with the digital speaker system or sound bar.
- 5 To turn off your TV speakers, on the **Home** menu, press **^** or **v** to highlight **Settings**, then press **OK**. Highlight **Audio**, then press **OK**. Highlight **TV speakers**, then press **OK**. Press **OK** to remove the check from the **TV speakers enabled** check box.
- 6 To configure the **HDMI 1 (ARC)** jack to output sound to an ARC device, on the **Home** menu, press **^** or **v** to highlight **Settings**, then press **OK**. Highlight **System**, then press **OK**. Highlight **Control other devices (CEC)**, then press **OK**. Highlight **HDMI ARC**, then press **OK** to check the box.



## Analog audio using the AUDIO OUT jack

When you connect an analog speaker system or sound bar to the **AUDIO OUT** jack, sound plays through the TV speakers and the audio device.

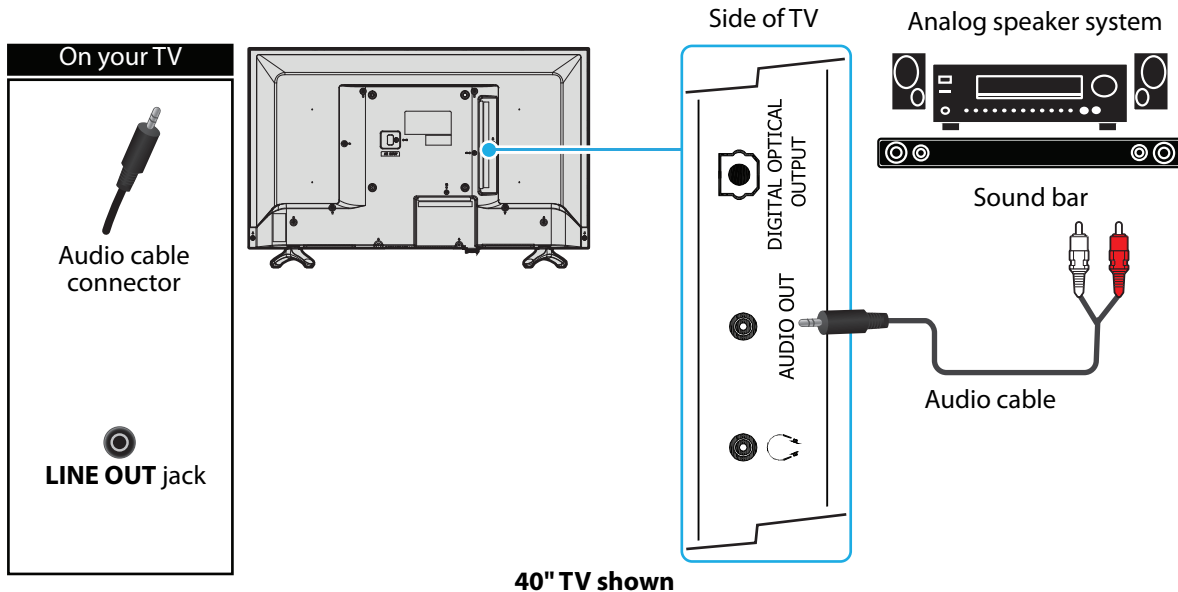

- 1 Make sure that your TV's power cord is unplugged and the analog speaker system or sound bar is turned off.
- 2 Connect an audio cable (not provided) to the **AUDIO OUT** jack on your TV and to the **AUDIO IN** jacks on the analog speaker system or sound bar.
- 3 Plug your TV's power cord into a power outlet, then turn on your TV.
- 4 Turn on the analog speaker system or sound bar, then set it to the correct source. For more information, see the documentation that came with the analog speaker system or sound bar.
- 5 To turn off your TV speakers, on the **Home** menu, press  $\wedge$  or  $\vee$  to highlight **Settings**, then press **OK**. Highlight **Audio**, then press **OK**. Highlight **TV speakers**, then press **OK**. Press **OK** to remove the check from the **TV speakers enabled** check box.

### Note

Use the volume controls on the analog speaker system or sound bar to control the volume.

# Connecting a home theater system with multiple devices

You can connect an AV receiver and your devices to create a home theater.

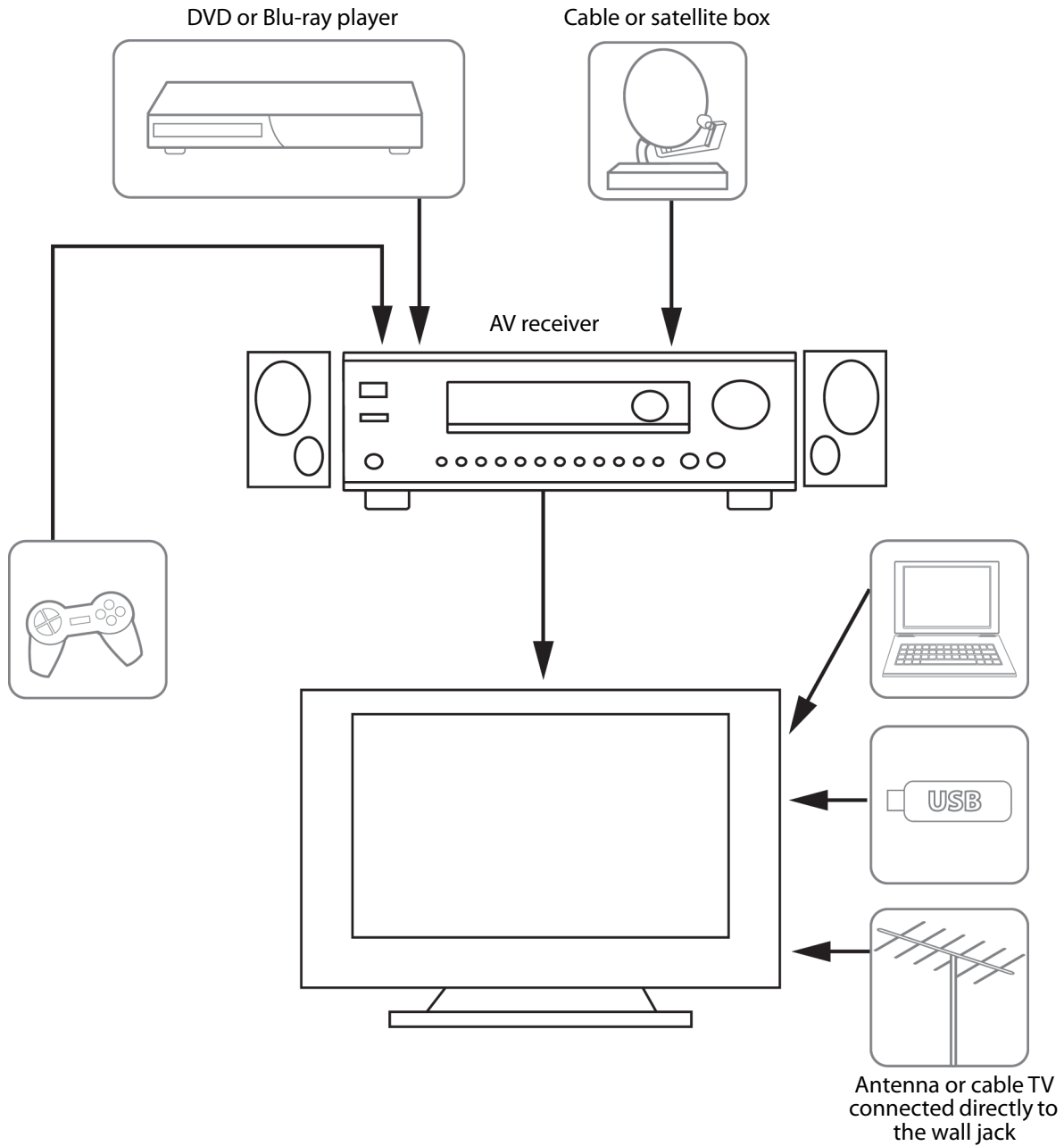

The connections you make depend on the video and audio jacks available on your devices. Refer to the documentation that came with your devices for connection information.

Just remember to use the best connection types available for the best picture and sound. For information about connection types, see [What connection should I use?](#) on page 16.

# SHARP • Roku TV

## Connecting power

LC-32LB601U/LC-32LB601C/LC-40LB601U  
32" HD LED 720p/40" Full HD LED 1080p Sharp Roku TV

You should connect devices **before** you connect the power cord. When you are adding devices, make sure that the power cord is unplugged from the power outlet.

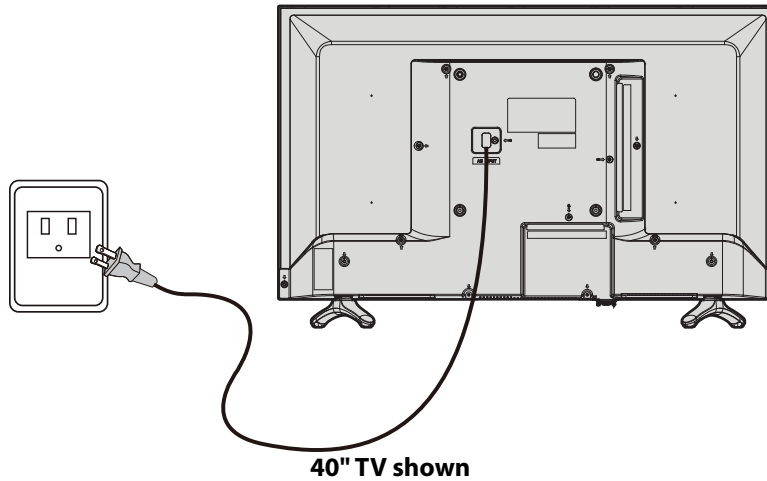

### 32" TV

- 1 Connect the power cord to the power connector on your TV.
- 2 Connect the other end of the cord to a power outlet.

#### Caution

- Your TV should only be operated from the power source indicated on the label.
- Always unplug the power cord from the power outlet when you will not be using your TV for an extended period of time.

### 40" TV

- Connect the power cord to a power outlet.

#### Caution

- Your TV should only be operated from the power source indicated on the label.
- Always unplug the power cord from the power outlet when you will not be using your TV for an extended period of time.
- The power cord is permanently attached to your TV. Do not try to unplug it from the back of your TV.

# Installing remote control batteries

Open the back of your TV remote control and insert two AAA batteries, observing the proper orientation. Reattach the back cover.

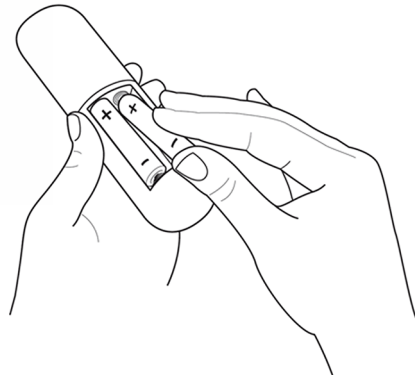

[Remote control](#) on page 14 explains how to use the remote control in each of your TV's operating modes.

## Cautions

- Batteries should not be exposed to excessive heat, such as sunshine, heat registers, or fire.
- Battery chemicals can cause a rash. If the batteries leak, clean the battery compartment with a cloth. If chemicals touch your skin, wash immediately.
- Make sure that batteries are disposed of correctly. Do not burn or incinerate.

## Notes

- Do not mix batteries of different types.
- Do not mix old and new batteries.
- Remove batteries when the charge is depleted.
- If the remote control is not going to be used for an extended period of time, remove the batteries.

## Aiming the remote control

- Point the remote control towards the remote sensor on the front of your TV.

# SHARP • Roku TV

## Setting up your TV

LC-32LB601U/LC-32LB601C/LC-40LB601U  
32" HD LED 720p/40" Full HD LED 1080p Sharp Roku TV

When you turn on your TV for the first time, Guided Setup starts. During Guided Setup:

- Your TV automatically detects your wireless network, so have your network name and password handy and follow the easy on-screen instructions.
- You'll be prompted to create your Roku account online at <https://my.roku.com/link>. Your TV generates a unique code that links your TV to your new account.

### Note

Roku accounts are free, and while a valid credit card number is not required, providing your card information makes renting and purchasing entertainment a breeze.

- After you are connected to your account, your TV automatically updates with the latest software, and you can start streaming immediately.

### Note

If you aren't ready to connect your TV to a wireless network, you can still use it as a regular TV.

## Using your TV

For more information about Guided Setup and using Roku, go to <https://go.roku.com/tvmanual>

## Maintaining

- Do not use your TV in areas that are too hot or too cold, because the cabinet may warp or the screen may malfunction. Your TV works best in temperatures that are comfortable to you.
- Storage temperatures are 5° to 113°F (-15° to 45°C).
- Working temperatures are 41° to 95°F (5° to 35°C).
- Do not place your TV in direct sunlight or near a heat source.

### Cleaning your TV cabinet

Clean the cabinet with a soft, lint-free cloth. If the cabinet is especially dirty, moisten a soft, lint-free cloth in a weak detergent solution, squeeze the excess moisture from the cloth, then wipe the cabinet with the cloth. Use a clean cloth to dry the cabinet.

### Cleaning your TV screen

Clean the screen with a soft, lint-free cloth.

# SHARP • Roku TV

## Troubleshooting

LC-32LB601U/LC-32LB601C/LC-40LB601U  
32" HD LED 720p/40" Full HD LED 1080p Sharp Roku TV

### Warning

Do not try to repair your TV yourself. Contact authorized service personnel.

### Note

If the problem is not solved by using these troubleshooting instructions, turn off your TV, then turn it on again.

### Note

If you have any other questions about how to use your TV that are not covered in this User Guide, go to <http://support.roku.com> and select your TV brand and model.

## FAQ

For the latest answers to Frequently Asked Questions, visit the Common Questions section at <https://www.sharptvusa.com/support> and the Support section of the Roku website (<https://support.roku.com/index>).

## Video and audio

| Symptom   | Possible cause   | Try this...  |
|---|--|--|
| Picture does not fill the screen or there are black bars around the picture | The picture size may need to be adjusted                       | <ul style="list-style-type: none"> <li>Adjust the picture size (aspect ratio). See the <b>Picture Size</b> option in the <i>Options</i> menu.</li> </ul>   |
| I don't see a picture when I select an input                                | TV is not on   | <ul style="list-style-type: none"> <li>Make sure that your TV is plugged into a working power outlet, and that your TV is turned on. (Your TV has a light on the front that indicates if your TV is turned off.)</li> </ul>  |
|   | Cables are not connected correctly                             | <ul style="list-style-type: none"> <li>Make sure that the video cables are connected correctly and securely to your TV.</li> <li>Make sure that the antenna or cable TV is connected correctly and securely. See <a href="#">Connecting a cable or satellite box</a> on page 17 or <a href="#">Connecting an antenna or cable TV (no box)</a> on page 20.</li> </ul> |
|   | Picture settings may be incorrect                              | <ul style="list-style-type: none"> <li>Adjust the contrast and brightness. See the <b>TV brightness</b> option in the <i>Settings</i> menu or <i>Options</i> menu.</li> <li>Adjust the TV picture.</li> </ul>  |
|   | Incorrect input may be selected                                | <ul style="list-style-type: none"> <li>Make sure that the correct input is selected for the device you want to view.</li> </ul>  |
|   | Input source not detected                                      | <ul style="list-style-type: none"> <li>Make sure that the device connected to the input is turned on.</li> <li>Make sure that the cord to and from the device is connected firmly and correctly to the device and your TV.</li> </ul>  |
|   | TV input may be bad  | <ul style="list-style-type: none"> <li>Connect a different device to the same input and check to see if it works correctly.</li> </ul>   |
| TV channel does not appear  | Broadcast TV may be experiencing problems or may not be set up | <ul style="list-style-type: none"> <li>Try another channel. The station may be experiencing problems.</li> <li>Make sure that the incoming signal is compatible.</li> <li>If you are trying to watch broadcast TV, make sure that Antenna TV is set up.</li> </ul>   |

| Symptom  | Possible cause   | Try this...   |
|--|--|---|
| Dark, poor, or no picture (screen is lit), but sound is good               | Broadcast TV may be experiencing problems or may not be set up | <ul style="list-style-type: none"> <li>Try another channel. The station may be experiencing problems.</li> <li>If you are using an antenna and the signal strength is low, adjust the antenna or use a highly directional outdoor antenna or set-top antenna with a built-in amplifier.</li> </ul>  |
|  | Cables may not be connected correctly                          | <ul style="list-style-type: none"> <li>Make sure that the antenna or cable TV is connected correctly and securely. See <a href="#">Connecting a cable or satellite box</a> on page 17 or <a href="#">Connecting an antenna or cable TV (no box)</a> on page 20.</li> <li>Make sure that the video cables are connected correctly and securely to your TV.</li> <li>The video cable(s) you are using may be bad. Try a new set.</li> </ul> |
|  | Picture settings may be incorrect                              | <ul style="list-style-type: none"> <li>Adjust the brightness. See the <b>TV brightness</b> option in the <i>Settings</i> menu or <i>Options</i> menu.</li> <li>Change to a different picture mode. See the <b>Picture mode</b> option in the <i>Options</i> menu or <i>Advanced Picture Settings</i> menu.</li> </ul>   |
| No color, dark picture, or color is not correct                            | Picture settings may be incorrect                              | <ul style="list-style-type: none"> <li>Adjust the contrast, color, and brightness settings. See the <b>TV brightness</b> option in the <i>Settings</i> menu or the <i>Options</i> menu.</li> </ul>  |
|  | Broadcast TV may be experiencing problems                      | <ul style="list-style-type: none"> <li>Try another channel. The station may be experiencing problems.</li> <li>If you are using an antenna and the signal strength is low, adjust the antenna or use a highly directional outdoor antenna or set-top antenna with a built-in amplifier.</li> </ul>  |
|  | Cables are not connected correctly                             | <ul style="list-style-type: none"> <li>Make sure that the antenna or cable TV is connected correctly and securely. See <a href="#">Connecting a cable or satellite box</a> on page 17 or <a href="#">Connecting an antenna or cable TV (no box)</a> on page 20.</li> <li>Make sure that the video cables are connected correctly and securely to your TV.</li> <li>The video cable(s) you are using may be bad. Try a new set.</li> </ul> |
| Only snow (noise) appears on the screen                                    | Broadcast TV may be experiencing problems or may not be set up | <ul style="list-style-type: none"> <li>Try another channel. The station may be experiencing problems.</li> <li>If you are trying to watch broadcast TV, make sure that Antenna TV is set up.</li> <li>If you are using an antenna and the signal strength is low, adjust the antenna or use a highly directional outdoor antenna or set-top antenna with a built-in amplifier.</li> </ul>   |
|  | Cables may not be connected correctly                          | <ul style="list-style-type: none"> <li>Make sure that the antenna or cable TV is connected correctly and securely. See <a href="#">Connecting a cable or satellite box</a> on page 17 or <a href="#">Connecting an antenna or cable TV (no box)</a> on page 20.</li> </ul>  |
| Picture quality is good on some channels and poor on others. Sound is good | Broadcast signal may be weak                                   | <ul style="list-style-type: none"> <li>If you connect to cable without a set-top box and experience poor picture quality, you may need to install a set-top box to improve signal reception and picture quality. Contact your cable TV provider about upgrading to a set-top box.</li> </ul>  |

| Symptom                                      | Possible cause   | Try this...  |
|--|--|--|
| Dotted lines or stripes appear on the screen | Cables may not be connected correctly  | <ul style="list-style-type: none"> <li>Make sure that the antenna or cable TV is connected correctly and securely. See <a href="#">Connecting a cable or satellite box</a> on page 17 or <a href="#">Connecting an antenna or cable TV (no box)</a> on page 20.</li> <li>Make sure that the video cables are connected correctly and securely to your TV.</li> <li>The video cable(s) you are using may be bad. Try a new set.</li> </ul>  |
|  | Broadcast signal may be weak   | <ul style="list-style-type: none"> <li>If you are using an antenna and the signal strength is low, adjust the antenna or use a highly directional outdoor antenna or set-top antenna with a built-in amplifier.</li> <li>Other devices (for example, a surround sound receiver, external speakers, fans, or hair dryers) may be interfering with your TV. Try turning off one device at a time to determine which device is causing interference. After you have determined which device is causing interference, move it further from your TV to eliminate the interference.</li> </ul>   |
| Double images                                | Broadcast signal may be weak   | <ul style="list-style-type: none"> <li>If you are using an antenna and the signal strength is low, adjust the antenna or use a highly directional outdoor antenna or set-top antenna with a built-in amplifier.</li> <li>If you are using an antenna and the signal strength is low, switch to a cable or satellite box.</li> </ul>  |
| The picture has a few bright or dark spots   | This is normal in LED TVs  | <ul style="list-style-type: none"> <li>A few bright or dark spots on a TV screen is normal. It does not affect the operation of your TV.</li> </ul>  |
| Good picture, but no sound                   | Volume is down or muted  | <ul style="list-style-type: none"> <li>Increase the volume.</li> <li>Make sure that the sound is not muted.</li> </ul>   |
|  | Headphones may be connected  | <ul style="list-style-type: none"> <li>Make sure that you do not have headphones connected. When headphones are connected, no sound comes from your TV speakers.</li> </ul>  |
|  | TV speakers may be turned off  | <ul style="list-style-type: none"> <li>If you want sound to play through your TV speakers, make sure that your TV speakers are turned on.</li> </ul>   |
|  | You may need to change the audio mode  | <ul style="list-style-type: none"> <li>Change to a different audio mode.</li> </ul>  |
|  | Home theater system, sound bar, or external speaker system may not be turned on or may not be set up correctly | <ul style="list-style-type: none"> <li>If you are using a home theater system, sound bar, or external speaker system, make sure that it is turned on and is not muted and that it is set to the correct source.</li> <li>If you connected an ARC audio device to the <b>HDMI 1 (ARC)</b> jack, make sure that you have turned on the ARC feature.</li> <li>If you are using a home theater system, sound bar, or external speaker system and have connected it with a digital audio cable, make sure that you have set up the digital audio connection.</li> <li>Make sure that the audio cables are connected correctly and securely to your TV.</li> </ul> |
|  | Bad content, no audio  | <ul style="list-style-type: none"> <li>Make sure that the selected channel or content is intended to be broadcasting with sound.</li> </ul>  |
|  | Cables may not be connected correctly  | <ul style="list-style-type: none"> <li>Make sure that the antenna or cable TV is connected correctly and securely. See <a href="#">Connecting a cable or satellite box</a> on page 17 or <a href="#">Connecting an antenna or cable TV (no box)</a> on page 20.</li> <li>The audio cables you are using may be bad. Try a new set.</li> </ul>  |



| Symptom             | Possible cause                                     | Try this...  |
|---------------------|--|--|
| Poor picture        | Light in the viewing area may be interfering       | <ul style="list-style-type: none"> <li>Make sure that the room is not too bright. Light reflecting off the screen can make the picture difficult to see.</li> </ul>  |
|                     | A connected camera or camcorder may be interfering | <ul style="list-style-type: none"> <li>If an S-VHS camera or a camcorder is connected while another connected device is turned on, the picture may be poor. Turn off one or more devices.</li> </ul>   |
| Audio noise         | Other devices may be interfering                   | <ul style="list-style-type: none"> <li>Other devices (for example, a surround sound receiver, external speakers, fans, or hair dryers) may be interfering with your TV. Try turning off one device at a time to determine which device is causing interference. After you have determined which device is causing interference, move it further from your TV to eliminate the interference.</li> </ul> |
| After images appear |  | <ul style="list-style-type: none"> <li>Do not display a still image, such as a logo, game, or computer image, for an extended period of time. This can cause a permanent after-image to be burned into the screen. This type of damage is not covered by your warranty.</li> </ul>   |

## Remote control

| Symptom  | Possible cause                                 | Try this...   |
|--|--|---|
| My TV doesn't turn on using the remote control             | No power to TV                                 | <ul style="list-style-type: none"> <li>Make sure that the power cord is correctly connected to both your TV power connector and power outlet. See <a href="#">Connecting power</a> on page 32. You should see an LED in the front of the TV panel when a button on the remote is pressed. If you see no LED activity, try another outlet or check your fuse box.</li> </ul> |
|  | Line-of-sight obstructed                       | <ul style="list-style-type: none"> <li>Make sure that no objects (or pets) are obstructing the line-of-sight from the remote control to the remote sensor on the front of your TV. See <a href="#">Aiming the remote control</a> on page 33.</li> </ul>   |
|  | Remote not responding                          | <ul style="list-style-type: none"> <li>Open the battery compartment and make sure that the batteries are seated in the correct positions (+ and - in the correct positions). See <a href="#">Installing remote control batteries</a> on page 33.</li> <li>Make sure that the batteries are fresh and working correctly. Replace the batteries, if necessary.</li> </ul>     |
|  | TV frozen                                      | <ul style="list-style-type: none"> <li>If the front LED is not responding, or abnormally bright, disconnect the power cord from the power outlet, wait a few seconds, then reconnect the power cord.</li> </ul>   |
| Trouble programming your existing universal remote control | Remote control may not be programmed correctly | <ul style="list-style-type: none"> <li>For instructions on programming a universal remote control, visit: <a href="http://www.roku.com/universalremote">www.roku.com/universalremote</a></li> <li>Refer to the User Guide that accompanied your universal remote control and contact the manufacturer if problems persist.</li> </ul>                                       |
|  | Batteries may be dead                          | <ul style="list-style-type: none"> <li>Replace dead batteries with new batteries. Refer to the User Guide that accompanied your universal remote control.</li> </ul>  |

## General

| Symptom   | Possible cause   | Try this...  |
|---|--|--|
| No power  | Power cord may not be connected correctly  | <ul style="list-style-type: none"> <li>Make sure that the power cord is correctly connected to your TV power connector (32" TV) and power outlet. See <a href="#">Connecting power</a> on page 32. You should see an LED in the front of your TV panel when a button on the remote is pressed. If you see no LED activity, try another outlet or check your fuse box.</li> <li>Unplug the power cord, wait 60 seconds, then plug the cord back in and turn on your TV.</li> </ul>                                      |
|   | Other devices may be interfering   | <ul style="list-style-type: none"> <li>Other devices (for example, a surround sound receiver, external speakers, fans, or hair dryers) may be interfering with your TV. Try turning off one device at a time to determine which device is causing interference. After you have determined which device is causing interference, move it further from your TV to eliminate the interference.</li> </ul>   |
| My TV tuner does not pick up as many over-the-air channels as it should | Antenna may not be placed optimally  | <ul style="list-style-type: none"> <li>Adjust the antenna location and rescan. Go to <b>Settings &gt; TV inputs &gt; Antenna TV &gt; Scan again for channels</b>.</li> <li>Reception can vary by channel depending on the broadcast power level of a given station. Contact your cable or satellite TV provider.</li> <li>Make sure that the antenna or cable/satellite TV is connected securely to your TV.</li> <li>Try replacing the cable between the antenna/cable or cable/satellite box and your TV.</li> </ul> |
|   | Broadcast TV may not be set up   | <ul style="list-style-type: none"> <li>Make sure that Antenna TV is set up.</li> </ul>   |
| One or more channels do not display                                     | Channels may be blocked or hidden  | <ul style="list-style-type: none"> <li>Make sure that the channels are not blocked.</li> <li>Make sure that the channels are not hidden. The channel may have been deleted from the channel list. You can add the channel back to the channel list.</li> </ul>   |
|   | The wrong input may be selected  | <ul style="list-style-type: none"> <li>Make sure that you have selected the correct input tile for the device or service you are trying to use.</li> </ul>   |
|   | You may need to use the remote control that came with the cable or satellite box | <ul style="list-style-type: none"> <li>If you are using a cable or satellite box, use the remote that came with that box to change channels.</li> </ul>  |
| I lost my parental control PIN  | Need PIN recovery  | <ul style="list-style-type: none"> <li>You will need to factory reset your TV, as the PIN cannot be recovered or reset any other way. Go to <b>Settings &gt; System &gt; Advanced system settings &gt; Factory reset</b>.</li> </ul>   |
| Some settings cannot be accessed  | Not all settings are available for all devices or inputs                         | <ul style="list-style-type: none"> <li>If the ✖ icon or a menu option is grayed, you cannot adjust settings for the current video input mode.</li> </ul>   |
| TV cabinet creaks   | This is normal   | <ul style="list-style-type: none"> <li>When your TV is in use, the temperature rises naturally and may cause the cabinet to expand or contract which can cause a creaking noise. This is not a malfunction.</li> </ul>   |
| Control buttons do not work   | TV may be frozen   | <ul style="list-style-type: none"> <li>Unplug the power cord, wait a few seconds, then plug the cord back in and turn on your TV.</li> </ul>   |
| TV keeps turning off  | Sleep timer may be turned on   | <ul style="list-style-type: none"> <li>Make sure that the sleep timer is not turned on.</li> </ul>   |

| Symptom                         | Possible cause                    | Try this...  |
|---------------------------------|-----------------------------------|--|
| Some features are not available | The wrong TV mode may be selected | <ul style="list-style-type: none"> <li>You may have <b>Set up for store mode</b> when you set up your TV. Store use mode is for retail environments only. In <b>Store use mode</b>, some of your TV's features are missing or limited. If you selected <b>Set up for store use</b> and you want to change to <b>Set up for home use</b>, you have to reset your TV to the factory defaults. Go to <b>Settings &gt; System &gt; Advanced system settings &gt; Factory reset</b>.</li> </ul> |

## Roku

| Symptom  | Possible cause                                 | Try this...   |
|--|--|---|
| How can I find out more about using my TV?     |  | <ul style="list-style-type: none"> <li>If you need help with using your TV or Roku, go to: <a href="https://go.roku.com/tvmanual">https://go.roku.com/tvmanual</a></li> </ul>                   |
| I can't turn my TV on with the Roku mobile app | Your TV is "asleep"                            | <ul style="list-style-type: none"> <li>You will need to use the physical remote button to "wake up" or turn on your TV.</li> </ul>  |
| I can't find my TV with the Roku mobile app    | TV and mobile app not on same wireless network | <ul style="list-style-type: none"> <li>Make sure that your TV and the mobile app are on the same network.</li> </ul>  |
|  | TV not powered or working normally             | <ul style="list-style-type: none"> <li>Make sure that your TV is connected to a working power outlet and that your TV is turned on. See <a href="#">Connecting power</a> on page 32.</li> </ul> |

## Network

| Symptom                                   | Possible cause                            | Try this...  |
|---|---|--|
| I cannot connect to the internet          | Network connection may not be set up      | <ul style="list-style-type: none"> <li>If you did not connect to the internet when you first set up your TV, set up a network connection.</li> </ul>   |
|   | Network name or password may have changed | <ul style="list-style-type: none"> <li>If your network name or password has changed, you need to update your network connection.</li> </ul>  |
| Streaming keeps pausing to load more data | Wireless LAN not optimized                | <ul style="list-style-type: none"> <li>Rotate wireless router slightly</li> <li>Elevate the router</li> <li>Turn off other wireless connections</li> <li>Use 5.0GHz, if possible. Roku TVs support dual band.</li> </ul> |
|   | Insufficient broadband speed              | <ul style="list-style-type: none"> <li>Turn off other wireless connections that may also be using bandwidth.</li> </ul>  |

## CEC-compatible devices

| Symptom   | Possible cause  | Try this...   |
|---|---|---|
| My TV is not displaying the video from the connected CEC device | Cables may not be connected correctly                     | <ul style="list-style-type: none"> <li>• Make sure that the HDMI® cable is connected securely to your TV and the device.</li> <li>• Make sure that the device is connected to your TV with an HDMI® cable.</li> </ul>   |
|   | Picture settings may be incorrect                         | <ul style="list-style-type: none"> <li>• Try adjusting your TV picture.</li> </ul>  |
|   | The selected input may be incorrect                       | <ul style="list-style-type: none"> <li>• Make sure that the correct input tile is selected.</li> </ul>  |
|   | Connected device may not be a CEC device                  | <ul style="list-style-type: none"> <li>• Make sure that the device is a CEC device. See the documentation that came with the device for more information.</li> </ul>  |
|   | CEC control may not be set up correctly                   | <ul style="list-style-type: none"> <li>• Make sure that your TV has searched for CEC devices.</li> </ul>  |
| My TV is not playing the audio from the connected CEC device.   | Cables may not be connected correctly                     | <ul style="list-style-type: none"> <li>• Make sure that the HDMI® cable is connected securely to your TV and the device.</li> </ul>   |
|   | Volume may be too low or muted                            | <ul style="list-style-type: none"> <li>• Make sure that the volume on your TV and the device is turned up and not muted.</li> </ul>   |
|   | TV speakers may be turned off                             | <ul style="list-style-type: none"> <li>• If you want sound to play through your TV speakers, make sure that your TV speakers are turned on.</li> </ul>  |
|   | Connected device may not be a CEC device                  | <ul style="list-style-type: none"> <li>• Make sure that the device is a CEC device. See the documentation that came with the device.</li> </ul>   |
|   | CEC control may not be set up correctly                   | <ul style="list-style-type: none"> <li>• Make sure that your TV has searched for CEC devices.</li> </ul>  |
|   | Connected audio device may not be set up correctly        | <ul style="list-style-type: none"> <li>• If you are using a home theater system, sound bar, or external speaker system, make sure that it is set to the correct source.</li> <li>• If you are using a home theater system, sound bar, or external speaker system and have connected it with a digital audio cable, make sure that you have set up digital audio.</li> <li>• If you connected an ARC audio device to the <b>HDMI 1 (ARC)</b> jack, make sure that you have turned on the ARC feature.</li> </ul> |
| My TV's remote control does not control the device              | Connected device may not be turned on                     | <ul style="list-style-type: none"> <li>• Make sure that the device is turned on.</li> </ul>   |
|   | Line-of-sight obstructed                                  | <ul style="list-style-type: none"> <li>• Make sure that no objects (or pets) are obstructing the line-of-sight from the remote control to the remote sensor on the front of your TV and the device.</li> </ul>  |
|   | Connected device may not support some or all CEC features | <ul style="list-style-type: none"> <li>• Depending on the device, all the buttons may not work.</li> <li>• The device may not support this feature. See the documentation that came with the device for more information.</li> </ul>  |
|   | CEC control may not be set up correctly                   | <ul style="list-style-type: none"> <li>• Make sure that your TV has searched for CEC devices.</li> <li>• If you are trying to control the volume on an HDMI® CEC audio receiver using your TV remote control, make sure that your TV speakers are turned on.</li> <li>• If you are trying to control the volume on an HDMI® CEC audio receiver using your TV remote control, make sure that the system audio control is turned on.</li> </ul>   |

| Symptom  | Possible cause  | Try this...   |
|--|---|---|
| The device does not show up in the CEC device list | Connected device may not be a CEC device                  | <ul style="list-style-type: none"> <li>• Make sure that the device is a CEC device. See the documentation that came with the device.</li> </ul>   |
|  | Cables may not be connected correctly                     | <ul style="list-style-type: none"> <li>• Make sure that the HDMI® cable is connected securely to your TV and the device.</li> <li>• Make sure that the device is connected to your TV with an HDMI® cable.</li> </ul> |
|  | CEC control may not be set up correctly                   | <ul style="list-style-type: none"> <li>• Make sure that your TV has searched for CEC devices.</li> </ul>  |
| My device does not turn off when I turn off my TV  | Connected device may not be a CEC device                  | <ul style="list-style-type: none"> <li>• Make sure that the device is a CEC device. See the documentation that came with the device.</li> </ul>   |
|  | Connected device may not support some or all CEC features | <ul style="list-style-type: none"> <li>• The device may not support this feature. See the documentation that came with the device for more information.</li> </ul>  |
|  | CEC control may not be set up correctly                   | <ul style="list-style-type: none"> <li>• Make sure that your TV has searched for CEC devices.</li> <li>• Make sure that system standby is turned on.</li> </ul>   |
| My TV does not turn on when I turn on my device    | Connected device may not be a CEC device                  | <ul style="list-style-type: none"> <li>• Make sure that the device is a CEC device. See the documentation that came with the device.</li> </ul>   |
|  | Connected device may not support some or all CEC features | <ul style="list-style-type: none"> <li>• The device may not support this feature. See the documentation that came with the device for more information.</li> </ul>  |
|  | CEC control may not be set up correctly                   | <ul style="list-style-type: none"> <li>• Make sure that your TV has searched for CEC devices.</li> <li>• Make sure that 1-touch play is turned on.</li> </ul>   |

# SHARP • Roku TV

## Specifications

LC-32LB601U/LC-32LB601C/LC-40LB601U  
32" HD LED 720p/40" Full HD LED 1080p Sharp Roku TV

### 32-inch (LC-32LB601U/LC-32LB601C)

Specifications are subject to change without notice.

#### Dimensions and weight

|                                    |   |
|------------------------------------|---|
| <b>Without stand<br/>H × W × D</b> | 17 × 28.9 × 2.8 in. (43.1 × 73.4 × 7 cm)<br>9.5 lbs (4.3 kg)    |
| <b>With stand<br/>H × W × D</b>    | 18.7 × 28.9 × 7 in. (47.4 × 73.4 × 17.8 cm)<br>9.7 lbs (4.4 kg) |

#### Screen

|  |                    |
|--|--------------------|
| <b>Screen size measured diagonally</b> | 31.5 in. (80 cm)   |
| <b>Panel</b>                           | LCD                |
| <b>Panel backlight type</b>            | LED                |
| <b>Panel 60 Hz vs. 120 Hz</b>          | 60Hz               |
| <b>Display resolution</b>              | 720p               |
| <b>Panel resolution</b>                | 1366 (H) × 768 (V) |
| <b>Aspect ratio</b>                    | 16:9               |
| <b>Contrast ratio (typical)—panel</b>  | 3,000:1            |
| <b>Comb filter</b>                     | 3d y/c digital     |
| <b>Response time</b>                   | 6.5 ms             |
| <b>Horizontal viewing angle</b>        | 178°               |
| <b>Vertical viewing angle</b>          | 178°               |

#### Tuner

|                |                 |
|----------------|-----------------|
| <b>Analog</b>  | NTSC            |
| <b>Digital</b> | ATSC, Clear-QAM |

#### Inputs

|                        |  |
|------------------------|--|
| <b>HDMI®</b>           | 3  |
| <b>Composite video</b> | 1  |
| <b>WiFi</b>            | Yes (built-in)<br>Dual-band, 802.11 A/B/G/N  |
| <b>USB</b>             | 1<br>Supports image format: JPEG, PNG, GIF audio format: AAC, MP3, WMA, WAV (PCM), FLAC, AIFF, AC3 (Dolby Digital) video format: MKV, MP4, MOV |
| <b>Antenna/Cable</b>   | 1  |

#### Outputs

|                      |             |
|----------------------|-------------|
| <b>Headphone</b>     | 1           |
| <b>Analog audio</b>  | 1           |
| <b>Digital audio</b> | 1 (optical) |
| <b>WiFi</b>          | Yes         |
| <b>Ethernet</b>      | No          |

#### Audio

|                          |                                    |
|--------------------------|------------------------------------|
| <b>Audio enhancement</b> | DTS TruSurround                    |
| <b>Speakers</b>          | Number: 2<br>Watts per channel: 5W |

#### Power

|                                     |                |
|-------------------------------------|----------------|
| <b>Power consumption ON</b>         | On: 34.8W      |
| <b>Power consumption in standby</b> | Standby: <0.5W |

#### Miscellaneous

|                                      |                        |
|--------------------------------------|------------------------|
| <b>OSD languages</b>                 | English/French/Spanish |
| <b>CEC control</b>                   | Yes                    |
| <b>Game Mode</b>                     | Yes                    |
| <b>Internet connectable</b>          | Yes                    |
| <b>V-Chip (version 2.0)</b>          | Yes                    |
| <b>Sleep timer</b>                   | Yes                    |
| <b>Text-to-Speech</b>                | Yes                    |
| <b>Channel labeling</b>              | No                     |
| <b>VESA mount (mm) (Hor. × Ver.)</b> | 200 × 200              |
| <b>VESA mount screws</b>             | M6 × 10 mm type        |

#### Note

The length of the wall-mount screws vary depending on the wall-mount bracket you purchased. See the instructions that came with the wall-mount bracket for screw lengths.

# SHARP • Roku TV

LC-32LB601U/LC-32LB601C/LC-40LB601U  
32" HD LED 720p/40" Full HD LED 1080p Sharp Roku TV

## 40-inch (LC-40LB601U)

Specifications are subject to change without notice.

### Dimensions and weight

|                                    |  |
|------------------------------------|--|
| <b>Without stand<br/>H × W × D</b> | 21.2 × 36.1 × 3.2 in. (53.8 × 91.8 × 8.1 cm)<br>14.8 lbs (6.7 kg)  |
| <b>With stand<br/>H × W × D</b>    | 22.9 × 36.1 × 7.6 in. (58.1 × 91.8 × 19.2 cm)<br>15.2 lbs (6.9 kg) |

### Screen

|  |                     |
|--|---------------------|
| <b>Screen size measured diagonally</b> | 39.6 in. (100.6 cm) |
| <b>Panel</b>                           | LCD                 |
| <b>Panel backlight type</b>            | LED                 |
| <b>Panel 60 Hz vs. 120 Hz</b>          | 60Hz                |
| <b>Display resolution</b>              | 1080p               |
| <b>Panel resolution</b>                | 1920 (H) × 1080 (V) |
| <b>Aspect ratio</b>                    | 16:9                |
| <b>Contrast ratio (typical)–panel</b>  | 4,000:1             |
| <b>Comb filter</b>                     | 3d y/c digital      |
| <b>Response time</b>                   | 8 ms                |
| <b>Horizontal viewing angle</b>        | 178°                |
| <b>Vertical viewing angle</b>          | 178°                |

### Tuner

|                |                 |
|----------------|-----------------|
| <b>Analog</b>  | NTSC            |
| <b>Digital</b> | ATSC, Clear-QAM |

### Inputs

|                        |  |
|------------------------|--|
| <b>HDMI®</b>           | 3  |
| <b>Composite video</b> | 1  |
| <b>WiFi</b>            | Yes (built-in)<br>Dual-band, 802.11 A/B/G/N  |
| <b>USB</b>             | 1<br>Supports image format: JPEG, PNG, GIF audio format: AAC, MP3, WMA, WAV (PCM), FLAC, AIFF, AC3 (Dolby Digital) video format: MKV, MP4, MOV |
| <b>Antenna/Cable</b>   | 1  |

### Outputs

|                      |             |
|----------------------|-------------|
| <b>Headphone</b>     | 1           |
| <b>Analog audio</b>  | 1           |
| <b>Digital audio</b> | 1 (optical) |
| <b>WiFi</b>          | Yes         |
| <b>Ethernet</b>      | No          |

### Audio

|                          |                                    |
|--------------------------|------------------------------------|
| <b>Audio enhancement</b> | DTS TruSurround                    |
| <b>Speakers</b>          | Number: 2<br>Watts per channel: 5W |

### Power

|                                     |                |
|-------------------------------------|----------------|
| <b>Power consumption ON</b>         | On: 57.4W      |
| <b>Power consumption in standby</b> | Standby: <0.5W |

### Miscellaneous

|                                      |                        |
|--------------------------------------|------------------------|
| <b>OSD languages</b>                 | English/French/Spanish |
| <b>CEC control</b>                   | Yes                    |
| <b>Game Mode</b>                     | Yes                    |
| <b>Internet connectable</b>          | Yes                    |
| <b>V-Chip (version 2.0)</b>          | Yes                    |
| <b>Sleep timer</b>                   | Yes                    |
| <b>Text-to-Speech</b>                | Yes                    |
| <b>Channel labeling</b>              | No                     |
| <b>VESA mount (mm) (Hor. × Ver.)</b> | 200 × 200              |
| <b>VESA mount screws</b>             | M6 × 10 mm type        |

#### Note

The length of the wall-mount screws vary depending on the wall-mount bracket you purchased. See the instructions that came with the wall-mount bracket for screw lengths.

# Legal notices

## Copyright

Portions © 2018 Best Buy and Roku, Inc. All rights reserved. ROKU, the ROKU Logo, and "NOW THIS IS TV." are trademarks and/or registered trademarks of Roku, Inc. Material in this User Manual is the property of Best Buy and its subsidiaries, and Roku, Inc. and is protected under US and International copyright and/or other intellectual property laws.

Reproduction or transmission of the materials, in whole or in part, in any manner, electronic, print, or otherwise, without the prior written consent of the Best Buy and Roku, Inc. is a violation of Best Buy and Roku, Inc.'s rights under the aforementioned laws.

No part of this publication may be stored, reproduced, transmitted or distributed, in whole or in part, in any manner, electronic or otherwise, whether or not for a charge or other or no consideration, without the prior written permission of Roku, Inc. and Best Buy.

Requests for permission to store, reproduce, transmit or distribute materials may be made to the following addresses:

Best Buy

7601 Penn Ave South

Richfield, MN 55423 U.S.A.

Roku, Inc.

150 Winchester Circle

Los Gatos, CA 95032

Best Buy, Roku, Inc. and any and all other Best Buy or Roku, Inc. product names, logos, slogans or marks are registered trademarks of Best Buy and its subsidiaries and Roku, Inc. All other trademarks are the property of their respective holders.

Product name: Sharp Roku TV

Document name: *Sharp Roku TV User Guide*

Document revision: 7.5

Publication date: 21 April, 2016

## Legal statement

Please note—your access and use of streaming content and channels via the Sharp Roku TV are governed by the Sharp Roku TV End User Agreement (see below). By using the Sharp Roku TV you agree to the following disclaimer. For the avoidance of doubt, the content set forth herein shall refer to all content and channels accessible and available on the Sharp Roku TV, including those available via the Roku® streaming platform, as well as broadcast cable.

Due to the various capabilities of the Sharp Roku TV, as well as limitations in the available content available therein, certain features, applications, and services may not be available on all Sharp Roku TVs, or in all territories. Some features on the Sharp Roku TV may also require additional peripheral devices or membership fees that are sold separately. Please visit the Sharp or Roku, Inc. websites for more information on the Sharp Roku TV and content availability. The services and availability of content on the Sharp Roku TV are subject to change from time to time without prior notice.

All content and services accessible through the Sharp Roku TV belong to third parties and are protected by copyright, patent, trademark and/or other intellectual property laws. Such content and services are provided solely for your personal noncommercial use. You may not use any content or services in a manner that has not been authorized by the content owner or service provider. Without limiting the foregoing, you may not modify, copy, republish, upload, post, transmit, translate, sell, create derivative works, exploit, or distribute in any manner or medium any content or services displayed through the Sharp Roku TV.

You expressly acknowledge and agree that your use of the Sharp Roku TV is at your sole risk and that the entire risk as to satisfactory quality, performance and accuracy is with you. The Sharp Roku TV and all third party content and services are provided "as is" without warranty of any kind, either express or implied. Sharp and Roku expressly disclaims all warranties and conditions with respect to the Sharp Roku TV content and services, either express or, implied, including but not limited to, warranties of merchantability, of satisfactory quality, fitness for a particular purpose, of accuracy, of quiet enjoyment, and non-infringement of third party rights. Sharp and Roku do not guarantee the accuracy, validity, timeliness, legality, or completeness of any content or service made available

through the Sharp Roku TV and does not warrant that the Sharp Roku TV, content or services will meet your requirements, or that operation of the Sharp Roku TV will be uninterrupted or error-free. Under no circumstances, including negligence, shall Sharp be liable, whether in contract or tort, for any direct, indirect, incidental, special or consequential damages, attorney fees, expenses, or any other damages arising out of, or in connection with, any information contained in, or as a result of the use of the device, or any content or service accessed by you or any third party, even if advised of the possibility of such damages.

Third party services may be changed, suspended, removed, terminated or interrupted, or access may be disabled at any time, without notice, and Sharp and Roku makes no representation or warranty that any content or service will remain available for any period of time. Content and services are transmitted by third parties by means of networks and transmission facilities over which Sharp and Roku have no control. Without limiting the generality of this disclaimer, Sharp and Roku expressly disclaims any responsibility or liability for any change, interruption, disabling, removal of or suspension of any content or service made available through the Sharp Roku TV. Sharp, Roku, the content providers, or the service providers may impose limits on the use of or access to certain services or content, in any case and without notice or liability. Any questions or requests for service relating to the content or services made available on the Sharp Roku TV should be submitted to the respective cable content or service provider or as described in the Sharp Roku TV *User Guide*.

In the event of a conflict between the [Sharp Roku TV End User Agreement and the terms set forth in this Legal Disclaimer, the Sharp Roku TV End User Agreement shall prevail and control in all circumstances.

## Roku TV End User License Agreement

**IMPORTANT: READ THIS AGREEMENT CAREFULLY IF YOU HAVE ANY SHARP ROKU TV ALSO REVIEW THE IMPORTANT PRODUCT INFORMATION GUIDE BEFORE POWERING UP YOUR SHARP ROKU TV FOR THE FIRST TIME.**

### Overview

This End User License Agreement ("**EULA**") between you and Roku, Inc. ("**Roku**") governs the use of: (a) your television which uses the Roku platform to play digital content over the Internet ("**Television**"), and (b) any firmware and software that have been pre-installed on the Television and the firmware and software updates Roku provides to you for the Television (collectively, the "**Software**"). By linking the Television to your account on Roku's website ("**Roku Account**") or using the Television, you are agreeing to this EULA. If you are a resident of the European Economic Area, by agreeing to this EULA, you expressly agree to waive your right to withdraw.

If you do not agree to this EULA, you do not have the right to use the Television or the Software. If you are within the allowable time period for returns under the applicable return policy, you may return the Television to your seller for a refund, subject to the terms of such return policy. You should perform a factory reset before you return it to erase data that may be stored on the Television. For instructions on how to reset your Television, please visit [www.roku.com/support](http://www.roku.com/support).

In this EULA, "**Channel**" means an application in the Roku Channel Store; "**Content**" means movies, television shows, music and other audio and visual materials and entertainment; "**Content Provider**" means any provider of Content; and "**Roku Channel Store**" means the storefront of applications provided by Roku via the Television's on-screen menu.

### Changes to This EULA

Roku may amend this EULA at any time in its discretion. Such amendments shall be effective immediately upon posting of the amended EULA on Roku's website or via the Television or your Roku Account, whichever occurs first. If you have a Roku Account that is linked to your Television, then in its option, Roku may also notify you of the amended EULA by sending a notice to the last email address you have provided to Roku. You agree to provide accurate and complete information if and when you set up your Roku Account, and you agree to promptly update your account information (including contact information) to keep it accurate and complete. You can do this at any time by signing in to your Roku Account. Following such posting or notice by any of the methods described above, continued use of your Television or Roku Account means you accept and agree to the amended EULA. If you do not agree to the amended EULA, Roku may not be able to provide updates, upgrades or enhancements to your Television, and you may not be able to continue using your Television or Roku Account.



### Permitted Use and Restrictions

The Television and the Software are for personal, non-commercial use only. Copying or redistribution of any Content delivered via the Television is strictly prohibited and we may prevent or restrict you from copying or re-distributing any elements of the Software or Content using digital rights management or other technologies. The Television and the Software are for use only in those countries where the manufacturer of your Television has authorized its sale. If you are using the Television and the Software outside of these countries, the rights granted under this EULA do not apply. Some of the Content Providers use technologies to verify your geographic location, and you may not be able to use the Television or the Software to access any Content outside of the country or location authorized by Roku or the Content Provider. Except as expressly provided under this EULA, you do not acquire any intellectual property or other proprietary rights in or to the Television, the Software or the Content, including any rights in patents, inventions, improvements, designs, trademarks, database rights or copyrights, nor do you acquire any rights in any confidential information or trade-secrets. All rights not expressly granted to you in this EULA are reserved by Roku or its applicable licensors. You may not remove, obscure, alter or conceal any trademark, logo, copyright or other proprietary notice in or on any Television, Software or Content.

The Software is proprietary to Roku or its third party licensors and may be used only with the Television. Subject to this EULA and, where appropriate, the applicable third party licenses, you have a non-exclusive, non-transferable license to run the Software and any updated versions provided to you by Roku, only in and as incorporated in the Television. This is a license and not a sale. You may not (a) copy, assign, sublicense, lease, sell or rent the Software, (b) distribute or otherwise transfer the Software except as incorporated in the Television, provided that, you do not retain any copies of the Software and the recipient reads and agrees to this EULA (including all amendments); (c) modify, adapt, translate, or create derivative works of the Software (except only to the extent any of the foregoing restriction is prohibited by applicable law or as may be permitted by the license terms governing any Separately Licensed Code included with the Software); (d) decompile, disassemble, reverse engineer or otherwise derive source code from the Software, except to the extent such actions cannot be prohibited under applicable law because they are essential to achieve inter-operability of the Software with another software program, and provided that the information obtained by you during such activities is (i) used only to achieve such inter-operability; (ii) not disclosed without Roku's prior written consent; and (iii) not used to create any software that is substantially similar to the Software; (e) defeat, bypass, circumvent or interfere with any security mechanism or access control measures, or (f) have any of the foregoing done for you by a third party. This license does not include the right to receive Software upgrades or updates. Your right to use the Television and the Software will immediately terminate upon your breach of this EULA.

### Software Updates

in its sole discretion, ROKU MAY PROVIDE UPDATES TO YOUR TELEVISION VIA the internet, including BUG FIXES AND UPDATES, CHANGES IN THE USER INTERFACE OR HOW YOU ACCESS CONTENT, AND OTHER CHANGES THAT MAY add, ALTER or remove functionalities and features. You acknowledge that these updates: (a) may happen automatically in the background at any time (and that they cannot be disabled by You); AND (b) will require an internet CONNECTION and You may incur additional data charges from the provider of the INTERNET CONNECTION. You understand that these updates are necessary to maintain compatibility with other updates to ROKU'S products or services and may be required for security reasons. by using the TELEVISION, you hereby AGREE to receive such updates.

### Separately Licensed Code

Certain software components of the Software are provided under separate third party license terms ("**Separately Licensed Code**") and your right to use such components is governed by such license terms. Please visit <https://www.roku.com/separatelylicensedcode> for more information.

### Voice Search

If downloaded to your phone or mobile device, the Roku mobile app allows you to use your voice to search for content on your Television using voice search. When you choose to use voice search, you agree that Roku and/or a third party vendor contracted by Roku have your consent to record, process and store your voice inputs (e.g., a recording and the interpretation of what was said), and use such voice inputs with other information about your Television (e.g., device identifier) to provide services related to voice search to you, to improve the accuracy and quality of the service, and as described in Roku's Privacy Policy. To learn more about voice search, visit the FAQ pages of Roku's website at [www.roku.com/support](http://www.roku.com/support).

**NO WARRANTY FROM ROKU; Limitation of LIABILITY**

YOUR warranty with respect to the Television is provided by THE TELEVISION'S MANUFACTURER, and not by Roku. ROKU OFFERS NO WARRANTY TO YOU UNDER THIS EULA. WITHOUT LIMITING THE GENERALITY OF THE FOREGOING DISCLAIMER, TO THE MAXIMUM EXTENT PERMITTED BY APPLICABLE LAW:

- (A) THE SEPARATELY LICENSED CODE AND THE SOFTWARE ARE PROVIDED "AS IS", WITH ALL FAULTS AND WITHOUT WARRANTY OF ANY KIND. ROKU DISCLAIMS ALL OTHER WARRANTIES AND CONDITIONS, INCLUDING THE IMPLIED WARRANTY OF MERCHANTABILITY, SATISFACTORY QUALITY, FITNESS FOR A PARTICULAR PURPOSE AND NON-INFRINGEMENT. ROKU DOES NOT GUARANTEE, REPRESENT, OR WARRANT THAT THE TELEVISION, THE SEPARATELY LICENSED CODE AND THE SOFTWARE WILL BE: (I) SECURE, VIRUS-FREE OR ERROR-FREE, OR (II) FREE FROM ATTACK OR SECURITY INTRUSION.
- (B) IN NO EVENT SHALL ROKU, ITS DIRECTORS, OFFICERS OR EMPLOYEES BE LIABLE TO YOU FOR PERSONAL INJURY OR PROPERTY DAMAGE, OR ANY SPECIAL, INCIDENTAL, EXEMPLARY, PUNITIVE, INDIRECT OR CONSEQUENTIAL DAMAGES OF ANY KIND ARISING OUT OF ANY TELEVISION, THE SEPARATELY LICENSED CODE, THE SOFTWARE, OR YOUR USE THEREOF; AND
- (C) YOU AGREE THAT (I) THE TOTAL CUMULATIVE LIABILITY OF ROKU, ITS DIRECTORS, OFFICERS AND EMPLOYEES UNDER THIS EULA, INCLUDING LIABILITY RELATING TO ALL TELEVISIONS LINKED TO YOUR ROKU ACCOUNT, AND THE SEPARATELY LICENSED CODE AND THE SOFTWARE IN SUCH TELEVISIONS, AND YOUR USE THEREOF, SHALL NOT EXCEED THE AMOUNT SET FORTH IN THE ROKU ACCOUNT TERMS AND CONDITIONS YOU AGREED TO FOR YOUR ROKU ACCOUNT, AND (II) ROKU, ITS DIRECTORS, OFFICERS AND EMPLOYEES SHALL NOT BE LIABLE TO YOU UNDER THIS EULA FOR ANY DIRECT DAMAGES ARISING OUT OF, OR IN CONNECTION WITH THE TELEVISION. THE FOREGOING LIMITATIONS SHALL APPLY EVEN IF THE REMEDY PROVIDED HEREIN FAILS ITS ESSENTIAL PURPOSE AND EVEN IF ROKU, ITS DIRECTORS, OFFICERS OR EMPLOYEES HAVE BEEN ADVISED OF THE POSSIBILITY OF SUCH LIABILITY.

Some jurisdictions do not allow exclusions OF CERTAIN warranties OR LIMITATIONS OF LIABILITY FOR CERTAIN TYPES OF DAMAGES, so SOME OF the ABOVE LIMITATIONS IN THIS SECTION MAY NOT apply to You. NOTHING IN THESE TERMS OF USE SHALL AFFECT ANY NON-WAIVABLE STATUTORY RIGHTS THAT APPLY TO YOU, AND You may also have other rights that vary from jurisdiction to jurisdiction.

### Export Controls

You agree not to download any Content or Software, nor otherwise export or re-export any Television or the Software into (or to a national or resident of) Cuba, Iraq, Libya, North Korea, Iran, Syria or any other country as to which the United States or your country has embargoed goods, or to anyone on the U.S. Treasury Department's List of Specially Designated Nationals or the U.S. Commerce Department's Table of Denial Orders or on similar restricted lists published by your government from time to time. By using any Television or the Software, you are representing and warranting that you are not located in, under the control of, or a national or resident of any such country or on any such list.

## Choice of Law; Dispute Resolution

- A. If you are a consumer and a resident in any country in the European Economic Area where the sale of the Television is expressly authorized by its manufacturer, this EULA does not apply to you.
- B. In all other cases, including if you are a resident of the United States (and its possessions and territories) or Canada, you agree that this EULA shall be governed by the laws of the State of California without regard to any conflict of laws principles that may provide the application of the law of another jurisdiction; and:
  1. You and Roku agree to be bound by the procedures set forth below to resolve any and all claims between you and Roku arising out of or relating to any aspect of this EULA, whether based in contract, tort, statute, fraud, misrepresentation or any other legal theory, including but not limited to, claims between you and Roku related to the Television and the Software. Each such claim is referred to individually as "Claim" and collectively as "Claims".
  2. **YOU AND ROKU AGREE THAT, EXCEPT FOR THE CLAIMS IDENTIFIED IN PARAGRAPH 4 OF THIS SECTION BELOW, ANY AND ALL CLAIMS BETWEEN YOU AND ROKU SHALL BE FINALLY SETTLED BY BINDING ARBITRATION.** The arbitration shall take place in Santa Clara County, California and shall be administered by the American Arbitration Association ("AAA") pursuant to the AAA's then-current rules, including (if applicable) the AAA's Supplementary Procedures for Consumer-Related Disputes. Please be aware there is no judge or jury in arbitration. Arbitration procedures are simpler and more limited than the rules applicable in court, and review of the arbitrator's decision by a court is limited. **YOU AND ROKU FURTHER AGREE THAT EACH OF YOU MAY BRING CLAIMS AGAINST THE OTHER ONLY ON AN INDIVIDUAL BASIS AND NOT AS A PLAINTIFF OR CLASS MEMBER IN ANY PURPORTED CLASS OR REPRESENTATIVE ACTION OR PROCEEDING. THE ARBITRATOR MAY NOT CONSOLIDATE OR JOIN MORE THAN ONE PERSON'S CLAIM AND MAY NOT PRESIDE OVER ANY CONSOLIDATED, REPRESENTATIVE OR CLASS PROCEEDING. ALSO, THE ARBITRATOR MAY AWARD RELIEF (INCLUDING MONETARY, INJUNCTIVE OR DECLARATORY RELIEF) ONLY ON AN INDIVIDUAL BASIS AND MAY NOT AWARD ANY FORM OF CONSOLIDATED, REPRESENTATIVE OR CLASS-WIDE RELIEF.** Notwithstanding any provision in these terms to the contrary, if the class-action waiver in this provision is deemed invalid or unenforceable, or if an arbitration is allowed to proceed on a class basis, then neither you nor Roku are entitled to arbitrate the Claims. This arbitration provision is subject to the Federal Arbitration Act. The arbitrator's award shall be binding on you and Roku, and may be entered in any court of competent jurisdiction.
  3. Information on AAA and how arbitration is initiated can be found at [www.adr.org](http://www.adr.org) or by calling 800-778-7879. For Claims between You and Roku of \$75,000 or less, you will be responsible for the initial arbitration filing fee, up to the amount of the initial filing fee if you were to initiate a lawsuit against Roku based on such Claims in court. If the arbitrator finds such Claims to be non-frivolous, Roku will pay any difference in such filing fees? plus the arbitrator fees. For Claims between You and Roku in excess of \$75,000, if you are able to demonstrate that the costs of arbitration will be prohibitive as compared to the costs of litigation, Roku will pay as much of your actual filing fees and the arbitrator fees for the arbitration as the arbitrator deems necessary to prevent the arbitration from being cost-prohibitive as compared to the cost of litigation.
  4. This agreement to arbitrate does not apply to any Claim (a) in which a party is attempting to protect its intellectual property rights (such as its patent, copyright, trademark, trade secret, or moral rights, but not including its privacy or publicity rights), or (b) that may be brought in small-claims court.
  5. If the agreement to arbitrate in this provision is found to be invalid, unenforceable or inapplicable to a given Claim between You and Roku, then any and all proceedings to resolve such Claim must be brought exclusively in a federal court of competent jurisdiction in the Northern District of California or in a state court in Santa Clara County, California. You hereby irrevocably consent to the exclusive jurisdiction and venue of such courts.

**6.30-Day Right to Opt Out:** You have the right to opt out of this agreement to arbitrate by sending a written notice of your decision to opt out to the following address: Legal Department, Roku, Inc., 150 Winchester Circle, Los Gatos, CA 95032, USA; provided that, such notice must be postmarked on or before the 30th day after the first to occur of the following events if you do not already have a Roku Account: (a) the date of purchase of Your Television, or (b) the date you create your Roku Account. If you have an existing Roku Account, all devices you choose to link to your Roku Account, and all services provided by Roku which are accessed using these devices, will be subject to this agreement to arbitrate. Your notice should include your full name, your current postal address, telephone number and email address, the product name and serial number for Your Television, and a copy of the original proof of purchase for your Television. If you timely send a notice in compliance with this paragraph 6, the agreement to arbitrate will not apply to either you or Roku. If you do not timely send this notice, then you agree to be bound by this agreement to arbitrate.

7. Notwithstanding any provision in this Agreement to the contrary, you agree that, if Roku seeks to delete or materially modify the agreement to arbitrate described herein, any such deletion or modification will not apply to any individual Claim of which you have notified Roku prior to such modification.

## Miscellaneous

Roku may transfer its rights and obligations under this EULA to another organization. You may only transfer your rights or your obligations under this EULA to another person if Roku agrees in writing. This EULA is between you and Roku. No other person shall have any rights to enforce these terms. Each of the paragraphs of this EULA operates separately. If any court or relevant authority decides that any of them are unlawful, the remaining paragraphs will remain in full force and effect. If Roku fails to insist that you perform any of your obligations under this EULA, or if Roku does not enforce its rights against you, or if Roku delays in doing so, that will not mean that Roku has waived its rights against you, or that you do not have to comply with those obligations. If Roku does waive a default by you, Roku will only do so in writing, but that will not mean that Roku will automatically waive any later default by you.

## Contact Information

If you wish to contact Roku, please send your correspondence by mail to

Roku, Inc.

150 Winchester Circle

Los Gatos, CA 95032

or by email to [customerservice@roku.com](mailto:customerservice@roku.com).

Last Updated: 21 April, 2016

## FCC Statement

**Note:** This equipment has been tested and found to comply with the limits for a class B digital Device, pursuant to part 15 of the FCC Rules. These limits are designed to provide reasonable protection against harmful interference in a residential installation. This equipment generates, uses, and can radiate radio frequency energy and, if not installed and used in accordance with the instructions, may cause harmful interference to radio communications. However, there is no guarantee that interference will not occur in a particular installation. If this equipment does cause harmful interference to radio or television reception, which can be determined by turning the equipment off and on, the user is encouraged to try to correct the interference by one or more of the following measures:

- Reorient or relocate the receiving antenna.
- Increase the separation between the equipment and the receiver.
- Connect the equipment into an outlet on a circuit different from that to which the receiver is connected.
- Consult the dealer or an experienced radio/TV technician for help.

## Warning

Changes or modifications not expressly approved by the party responsible for compliance could void the user's authority to operate the equipment.

## Cables

Connections to this device must be made with shielded cables with metallic RF/EMI connector hoods to maintain compliance with FCC Rules and Regulations.

# SHARP • Roku TV

LC-32LB601U/LC-32LB601C/LC-40LB601U  
32" HD LED 720p/40" Full HD LED 1080p Sharp Roku TV

## Macrovision statement

This product incorporates copyright protection technology that is protected by U.S. patents and other intellectual property rights. Use of this copyright protection technology must be authorized by Macrovision, and is intended for home and other limited viewing uses only unless otherwise authorized by Macrovision. Reverse engineering or disassembly is prohibited.

U.S. Patent Nos. 5,583,936; 6,836,549; 5,315,448; 6,381,747; 6,501,842; and 7,050,698.

## Dolby License Notice and Trademark Acknowledgement

 **DOLBY AUDIO**™ Manufactured under license from Dolby Laboratories. Dolby, Dolby Audio, and the double-D symbol are trademarks of Dolby Laboratories.

## DTS TruSurround™



For DTS Patents, see <http://patents.dts.com>.  
Manufactured under license from DTS Licensing Limited. DTS, the Symbol, & DTS and the Symbol together are registered trademarks and DTS TruSurround is a trademark of DTS, Inc. © DTS, Inc. All Rights Reserved.

## HDMI®



The terms HDMI and HDMI High-Definition Multimedia Interface, and the HDMI Logo are trademarks or registered trademarks of HDMI Licensing LLC in the United States and other countries.

## Roku®



Roku and the Roku logo are registered trademarks of Roku, Inc. in the United States and other countries.

# SHARP • Roku TV

## One-year limited warranty - Sharp Televisions

LC-32LB601U/LC-32LB601C/LC-40LB601U  
32" HD LED 720p/40" Full HD LED 1080p Sharp Roku TV

- Consumables, including but not limited to batteries (i.e. AA, AAA, C etc.)
- Products where the factory applied serial number has been altered or removed
- Loss or Theft of this product or any part of the product
- Failures or Damage caused by any contact including but not limited to liquids, gels or pastes.
- Up to three (3) pixel failures (dots that are dark or incorrectly illuminated) grouped in an area smaller than one tenth (1/10) of the display size or up to five (5) pixel failures throughout the display. (Pixel based displays may contain a limited number of pixels that may not function normally.)
- Problems with delay in motion or action of video images while playing first-person style video games.

### Definitions:

Best Buy ("Warrantor") warrants to you, the original purchaser of this new Sharp-branded television ("Product"), that the Product shall be free of defects in the original manufacturer of the material or workmanship for a period of one (1) year from the date of your purchase of the Product ("Warranty Period"). For this warranty to apply, your Product must be purchased in the United States or Canada from a Best Buy authorized dealer of Sharp brand products only that are packaged with this warranty statement.

### How long does the coverage last?

The Warranty Period lasts for 1 year (365 days) from the date you purchased the Product. Your purchase date is printed on the receipt you received with the Product.

### What does this warranty cover?

During the Warranty Period, if the original manufacture of the material or workmanship of the Product is determined to be defective by an authorized Warrantor repair center or store personnel, Warrantor will (at its sole option): (1) repair the Product with new or rebuilt parts; or (2) replace the Product at no charge with new or rebuilt comparable products or parts. Products and parts replaced under this warranty become the property of Warrantor and are not returned to you. If service of Products or parts are required after the Warranty Period expires, you must pay all labor and parts charges. This warranty lasts as long as you own your Sharp Product during the Warranty Period. Warranty coverage terminates if you sell or otherwise transfer the Product.

### How to obtain warranty service?

If you purchased the Product at a Best Buy retail store location and your television Product has a screen size of less than 42 inches, please take your original receipt and the Product to any Best Buy store. Make sure that you place the Product in its original packaging or packaging that provides the same amount of protection as the original packaging. If you purchased the Product from a Best Buy online web site, mail your original receipt and the Product to the address listed on the web site. Make sure that you put the Product in its original packaging or packaging that provides the same amount of protection as the original packaging.

To obtain in-home warranty service for a television with a screen 42 inches or larger, in the United States call 1-888-BESTBUY or for Canada call 1-866-BESTBUY. Call agents will diagnose and correct the issue over the phone or will have an Sharp-approved repair technician dispatched to your home.

### Where is the warranty valid?

This warranty is valid only in the United States and Canada at Best Buy branded retail stores or websites to the original purchaser of the product in the county where the original purchase was made.

### What does the warranty not cover?

This warranty does not cover:

- Customer instruction/education
- Installation
- Set up adjustments
- Cosmetic damage
- Damage due to acts of God, such as power surges
- Accident(s)
- Misuse, unintentional or intentional
- Abuse, unintentional or intentional
- Negligence
- Commercial purposes/use, including but not limited to use in a place of business or in communal areas of a multiple dwelling condominium or apartment complex, or otherwise used in a place of other than a private home.
- Modification of any part of the Product, including the antenna
- Damage due to incorrect operation or maintenance
- Connection to an incorrect voltage or power supply
- Outages, static or other problems with over-the-air reception of the television broadcast signals.
- Attempted repair by any person not authorized by Warrantor to service the Product
- Products sold "as is" or "with all faults"

REPAIR REPLACEMENT AS PROVIDED UNDER THIS WARRANTY IS YOUR EXCLUSIVE REMEDY FOR BREACH OF WARRANTY. WARRANTOR SHALL NOT BE LIABLE FOR ANY INCIDENTAL OR CONSEQUENTIAL DAMAGES FOR THE BREACH OF ANY EXPRESS OR IMPLIED WARRANTY ON THIS PRODUCT, INCLUDING, BUT NOT LIMITED TO, LOST DATA, LOSS OF USE OF YOUR PRODUCT, LOST BUSINESS OR LOST PROFITS. WARRANTOR MAKES NO OTHER EXPRESS WARRANTIES WITH RESPECT TO THE PRODUCT, ALL EXPRESS AND IMPLIED WARRANTIES FOR THE PRODUCT, INCLUDING, BUT NOT LIMITED TO, ANY IMPLIED WARRANTIES OF AND CONDITIONS OF MERCHANTABILITY AND FITNESS FOR A PARTICULAR PURPOSE, ARE LIMITED IN DURATION TO THE WARRANTY PERIOD SET FORTH ABOVE AND NO WARRANTIES, WHETHER EXPRESS OR IMPLIED, WILL APPLY AFTER THE WARRANTY PERIOD. SOME STATES, PROVINCES AND JURISDICTIONS DO NOT ALLOW LIMITATIONS ON HOW LONG AN IMPLIED WARRANTY LASTS, SO THE ABOVE LIMITATION MAY NOT APPLY TO YOU. THIS WARRANTY GIVES YOU SPECIFIC LEGAL RIGHTS, AND YOU MAY ALSO HAVE OTHER RIGHTS, WHICH VARY FROM STATE TO STATE OR PROVINCE TO PROVINCE.

Product information:

<https://www.sharptvusa.com/support>

Product support 1-855-544-2030

©2018 Best Buy China LTD. All rights reserved.

This product is manufactured for Best Buy China Ltd, as trustee for Best Buy China, and distributed and warranted by Best Buy Purchasing, LLC (7601 Penn Avenue South, Richfield, Minnesota, U.S.A. 55423-3645) under brand license by SHARP Corporation.

SHARP is a registered trademark of Sharp Corporation; used under license by Hisense International (Hong Kong) America Investment Co., Limited

All other trademarks are property of their respective owners.

# SHARP • Roku TV

For product inquiries or accessibility assistance, please contact us with the information below:

<https://www.sharptvusa.com/support>  
1-855-544-2030

This product is manufactured for Best Buy China Ltd, as trustee for Best Buy China, and distributed and warranted by Best Buy Purchasing, LLC (7601 Penn Avenue South, Richfield, Minnesota, U.S.A. 55423-3645) under brand license by SHARP Corporation.

©2018 Best Buy China LTD. All rights reserved.

SHARP is a registered trademark of Sharp Corporation; used under license by Hisense International (Hong Kong) America Investment Co., Limited

All other trademarks are property of their respective owners.